

# UPPER MOKELUMNE RIVER WATERSHED AUTHORITY

## REQUEST FOR PROPOSAL (RFP) No. 18 - 04 for Cabbage Patch Thinning and Mastication

Contact Person: Karen Quidachay, Project Manager  
Phone Number: 530-295-8124  
E-mail Address: karenq@innercite.com

### RESPONSE DUE

by

**4:00 p.m.**

on

**June 29, 2018**

at

**UMRWA**

*(co-located with EBMUD Mokelumne Watershed and Recreation Office)*

**15083 Camanche Parkway South**

**Valley Springs, CA 95252.**

# UPPER MOKELUMNE RIVER WATERSHED AUTHORITY

**RFP No. 18 - 04**  
**for**  
**Cabbage Patch Thinning and Mastication**  
**TABLE OF CONTENTS**

<b>I.</b>	<b>STATEMENT OF WORK .....</b>	<b>3</b>
	A. PROPOSER QUALIFICATIONS .....	3
	B. SCOPE.....	3
	C. SPECIFIC REQUIREMENTS .....	3
<b>II.</b>	<b>CALENDAR OF EVENTS .....</b>	<b>5</b>
	A. SITE VISIT .....	6
	B. PRE-PROPOSAL MEETING and CONTRACTOR WORKSHOP .....	6
	C. PRE-WORK CONFERENCE .....	6
<b>III.</b>	<b>AUTHORITY PROCEDURES, TERMS, AND CONDITIONS .....</b>	<b>6</b>
	A. RFP ACCEPTANCE AND AWARD.....	6
	B. EVALUATION CRITERIA/SELECTION COMMITTEE .....	7
	C. PRICING.....	8
	D. PROTESTS.....	9
	E. INVOICING .....	10
<b>IV.</b>	<b>RFP RESPONSE SUBMITTAL INSTRUCTIONS AND INFORMATION .....</b>	<b>10</b>
	A. AUTHORITY CONTACTS.....	10
	B. SUBMITTAL OF RFP RESPONSE .....	10
	C. RESPONSE FORMAT .....	11

**ATTACHMENTS:**

EXHIBIT A - RFP RESPONSE PACKET

EXHIBIT B - INSURANCE REQUIREMENTS

EXHIBIT C - GENERAL SERVICES AGREEMENT: GENERAL REQUIREMENTS, TIMBER REMOVAL  
SPECIFICATIONS, SPECIFICATIONS FOR OPERATIONS, ROAD MAINTENANCE  
T-SPECIFICATIONS

PROJECT MAP (Separate Document)

## I. STATEMENT OF WORK

### A. PROPOSER QUALIFICATIONS

1. Proposer Minimum Qualifications:
  - a. Proposer, Proposer's principal, or Proposer's staff shall have been regularly engaged in the business of mechanical thinning and mastication within forest environments for at least 3 years.
  - b. Proposer shall possess all permits, licenses, and professional credentials necessary to perform services as specified under this RFP.

### B. SCOPE

It is the intent of these specifications, terms, and conditions to describe the services UMRWA is seeking. The Upper Mokelumne River Watershed Authority (Authority) intends to award a contract to the Proposer(s) who best meets the Authority's requirements.

The term of the contract shall begin on the date the contract is executed by the Authority and terminates on December 31, 2019.

This project lies entirely within Stanislaus National Forest Lands, on the Calaveras Ranger District. The Authority is implementing this project under a Supplemental Project Agreement pursuant to Master Stewardship Agreement #16-SA-11052000-065 between the Authority and the Forest Service.

This project consists of areas requiring the following: thinning and mastication of all live and dead brush, and coniferous trees less than 10" diameter breast height (DBH) to a 20 x 20 foot spacing in order to reduce fuel loading which is leading to a high risk of increased wildfire severity, intensity, and frequency.

Specifications for Treatments are described below. Additional specifications are described in Exhibit C General Services Agreement. Units are included in Exhibit C General Services Agreement. A project map is provided separately as the last attachment to this RFP.

### C. SPECIFIC REQUIREMENTS

#### Mastication

Item Number	Description	Unit of Measure	Quantity
1	Thinning and Mastication	Acres	132.3

**Item 1. Thinning and Mastication**

- a. Unit boundaries are identified with orange flagging.
- b. Masticate all live and dead brush, and coniferous trees less than 10" dbh to a 20 x 20 foot spacing.
- c. Trees are to be retained within the spacing described above in the following priority: 1) Sugar pine 2) Western white pine, 3) Jeffery/Ponderosa pine, 4) Incense cedar, 5) Red fir, 6) White fir, 7) Lodgepole pine. Retained trees shall be free of damage and defect. If all trees inside the spacing have defect or damage, retain the healthiest tree with highest species priority. Damage includes but is not limited to broken tops, broken branches, trunk scars and previous mechanical damage. Defect includes but is not limited to forked tops, crooks, conks, cankers, mistletoe and blister rust. Retain all Hardwood trees.
- d. All trees marked with orange or red paint are designated leave trees and shall not be damaged or felled. Protection of the residual trees shall be the highest priority in all operations.
- e. Mastication equipment is prohibited within 15' of high water mark of perennial, intermittent, and ephemeral streams. Equipment shall not cross meadows, "wet" stream channels, or other non-work areas. Riparian vegetation shall not be shredded, cut or damaged.
- f. All brush and coniferous trees shall be cut below the lowest live branch and have a stump height no higher than 6 inches above ground level on the uphill side or 8 inches above obstacles (i.e. large rocks, down logs).
- g. All woody shrubs/brush dead or alive with the exception of brush occurring within 1 foot of any wildlife log or tree not designated for treatment under the specifications of this agreement will be treated. Brush, small live and dead trees, and slash shall not be pushed into leave trees and left unshredded.
- h. Debris resulting from the operation shall lie flat on the ground and not exceed 12 inches in depth. No masticated or cut material shall lean against or be suspended by a leave tree. The masticated/shredded material shall be evenly distributed over the treated areas so as to not leave large accumulations of slash. Concentrations of brush, slash, and small dead trees may need repeated treatment in order to satisfy desired work standards.
- i. No individual piece of slash or vegetative debris shall be greater than 3 feet in length.
- j. Contractor shall not operate in areas within the units that exceed 40% slope.
- k. Soil displacement shall be minimized by working the shredding equipment in as straight a line as possible, up and down slopes, given the known limitations of residual trees and terrain. Waterbars in skid trails, firelines, and roads disturbed by the operations shall be restored to condition prior to damage.
- l. Hardwoods (Black oak, Aspen, Willow, Dogwood) shall not be masticated, shredded, or damaged, and shall be included as crop trees to meet spacing requirements.
- m. Do not masticate or otherwise damage any down logs greater than 12" diameter at the mid-section of the log, or snags greater than 15" DBH.
- n. Equipment shall be kept free of debris accumulations that may result in fire starts.
- o. Soils in the operating area must be dry enough to prevent rutting by a single pass of the equipment.
- p. Road signs indicating warning of work in progress are required at the beginning of any road and/or OHV trail while the operator is working in the vicinity and material from operator's work might cause a hazard to the general public using these trails/roads.

**Equipment Requirements**

- a. Contractor will provide cutting tools and equipment that are suitable for the job and minimize soil disturbance.
- b. Unless otherwise agreed, ground-based mastication equipment shall have a factory rated ground pressure of 8 psi or less and a grapple or thumb and mastication head mounted on an articulating boom capable of reaching at least 20 feet. The power head(s) on the equipment shall be able to complete specified work. This will include completing project area by minimizing ground impact with tracked equipment and power head(s). Equipment shall be capable of operating on slopes up to 40%.
- c. All equipment and power tools shall comply with Fire Precautions and Control.

**Resource Protection Measures.**

Unless otherwise agreed, no operations will be permitted within areas identified as CA-1 on the Project Map and/or flagged with orange/white and blue/black candy striped flagging and/or behind "Area Controlled" signs.

**Limited Operating Period**

Limited operating periods (LOPs) described below apply to the operations within all project areas as designated on the Project Map, unless waived by the Forest Service.

- a. Controlled Area CA3: No Operations between March 1 and August 15, inclusive.
- b. Controlled Area CA4: No Operations between February 15 and September 15, inclusive.

**Road Use Applicable to All Items**

All roads leading into each project area are to be kept open and free of any debris that may occur as a result of the work.

**Additional Specifications for Operations: Applies to all items.**

- a. Refer to Exhibit C General Services Agreement.

**II. CALENDAR OF EVENTS**

<b>EVENT</b>	<b>DATE/LOCATION</b>
<b>RFP Issued</b>	May 28, 2018
<b>Pre-Proposal Meeting</b>	June 19, 2018 3:15 p.m., Amador County Administrative Center, 810 Court Street, Jackson CA
<b>Response/Proposal Due</b>	June 29, 2018, by 4:00 p.m.
<b>Pre-work Conference</b>	No less than 10 days prior to operations starting
<b>Anticipated Contract Start Date</b>	August 4, 2018
<b>Contract Termination Date</b>	December 31, 2019

For process flexibility, note that all CALENDAR dates are subject to change.

**A. SITE VISIT**

Proposer is strongly encouraged to perform an independent site visit to the units to be treated in order to view the project setting and understand the site conditions and other factors potentially relevant to responding to this RFP.

**B. PRE-PROPOSAL MEETING and CONTRACTOR WORKSHOP**

Contractor Workshop: June 19, 2018 2:00 p.m., a workshop for prospective contractors regarding forestry and fuels reduction contracting with UMRWA pursuant to the Master Stewardship Agreement with the Forest Service.

Pre-proposal Meeting: June 19, 2018 3:15 p.m., a meeting to address questions from prospective contractors and discuss relevant UMRWA RFPs.

Location: Amador County Administrative Center, 810 Court Street, Jackson CA

**C. PRE-WORK CONFERENCE**

Proposer agrees that if awarded a contract, Proposer and its principals will attend a pre-work conference with UMRWA prior to starting operations to discuss job requirements.

**III. AUTHORITY PROCEDURES, TERMS, AND CONDITIONS****A. RFP ACCEPTANCE AND AWARD**

1. RFP responses will be evaluated by a committee and will be scored/ranked in accordance with the RFP section entitled "Evaluation Criteria/Selection Committee."
2. The committee will recommend award to the Proposer who, in its opinion, is best qualified to perform the work described in this RFP. Award may not necessarily be made to the Proposer with the lowest overall cost.
3. The Authority reserves the right to award to a single or to multiple General Service Providers, dependent upon what is in the best interest of the Authority.
4. The Authority has the right to decline to award this contract or any part of it for any reason.
5. Any specifications, terms, or conditions issued by the Authority, or those included in the Proposer's submission, in relation to this RFP, may be incorporated into any contract that may be awarded as a result of this RFP.
6. Award of contract. The right is reserved to reject any or all proposals, or to accept one part of a proposal and reject the other, unless the bidder stipulates to the contrary, and to waive technical defects, as the interest of the Authority may require. Award will be made by the UMRWA Board of Directors on or about July 27, 2018.

## B. EVALUATION CRITERIA/SELECTION COMMITTEE

All proposals will be evaluated by the Selection Committee. The SC may be composed of Authority staff and other individuals who have expertise or experience in this type of procurement. The SC will select/recommend a Proposer in accordance with the evaluation criteria set forth in this RFP. The evaluation of the RFP responses shall be within the sole judgment and discretion of the SC.

RFP responses will be evaluated and scored by the SC according to each Evaluation Criteria below, and scored according to the scoring worksheet shown below. The scores for each Evaluation Criteria will be added to arrive at the weighted score for each RFP response. An RFP response with a high weighted total will be deemed of higher quality than one with a lesser-weighted total.

	<p><b>Evaluation Criteria:</b> Each Proposer's project approach will be evaluated based on the entire set of factors listed below in A through D.</p>
<p><b>A.</b></p>	<p><b>Approach and Technical Criteria:</b></p> <ol style="list-style-type: none"> <li>1. <b>Approach:</b> Has the Proposer demonstrated a thorough understanding of the purpose and scope of the project? Additional credit may be given for the identification and planning for mitigation of schedule risks that the Proposer believes may adversely affect any portion of the Authority's schedule such as accounting for fire danger shutdowns, weather, or imposed contractual wildlife limitations.</li> <li>2. <b>Schedule:</b> The likelihood that the Proposers' implementation plan and schedule will meet the Authority's schedule based on the daily production and capacity needed to complete the project and fulfill all contractual obligations by the termination date.</li> <li>3. <b>Fire Prevention:</b> Have all Proposers' woods employees received the requisite firefighter training necessary to take action in the event of an operations fire, using the fire preventive equipment required in Exhibit C, Fire Precautions and Control?</li> <li>4. <b>Equipment:</b> Does Proposer possess the necessary equipment to be used to accomplish the specified and prescriptive work as described in this RFP solicitation?</li> </ol>
<p><b>B.</b></p>	<p><b>Cost:</b></p> <p>The points for Cost will be computed by dividing the amount of the lowest responsive RFP response received by each Proposer's total proposed cost.</p> <p>While not reflected in the Cost evaluation points, an evaluation may also be made of:</p> <ol style="list-style-type: none"> <li>1. Reasonableness (i.e., does the proposed pricing accurately reflect the Proposer's effort to meet requirements, objectives and what is considered to be common in the area?);</li> <li>2. Realism (i.e., is the proposed cost appropriate to the nature of the products and services to be provided?); and</li> <li>3. Affordability (i.e., the ability of the Authority to finance this project).</li> </ol> <p>Consideration of price in terms of overall affordability may be controlling in</p>

	circumstances where two or more RFP responses are otherwise judged to be equal, or when a superior RFP response is at a price that the Authority cannot afford.
<b>C.</b>	<p><b>Relevant Experience:</b></p> <ol style="list-style-type: none"> <li><b>Proposer Experience:</b> To what extent does Proposer have prior experience with similar projects and comparable work? Has the Proposer worked on USFS lands, has it completed projects on time? Does the Proposer effectively coordinate with field personnel to address operational questions and related issues in a timely fashion?</li> <li><b>Key Personnel and Quality Control Plan:</b> Do the individuals and Field Supervisor assigned to the project have experience on similar projects and how extensive is their experience in applying complex forestry silvicultural prescriptions, such as designation by description or prescription.</li> </ol>
<b>D.</b>	<p><b>References (See Exhibit A – RFP Response Packet):</b></p> <p>If a short list process is used for a solicitation, references are only performed on the shortlisted Proposers and the score for reference checks is not included in the preliminary short list score.</p>

#### Proposal Scoring Worksheet (100-point maximum score)

Score Weighting	%
A. Approach and Technical Criteria	40
B. Cost	30
C. Relevant Experience	20
D. References	10
Sum Total Score	100
Add 5% - Local Service Provider preference	Up to 5 points

A five percent (5%) preference will be applied to the scoring evaluation of proposals submitted by qualified Local Service Providers: the initial Sum Total Score will be adjusted upward by 5% (for example, a LSP proposal evaluation score of 80 would be increased 5% to 84%).

In order to qualify for consideration with this preference, a business enterprise must submit a completed Declaration of Local Service Provider and meet the following criteria:

- Where available, a valid business license issued from Amador, Calaveras or Alpine County or a political subdivision within these counties; and
- Its principal business office, or a satellite office from which the business enterprise operates or performs business on a day-to-day-basis, physically located within Amador, Calaveras or Alpine County.

#### **C. PRICING**

- Prices quoted shall be firm for the term of any contract that may be awarded pursuant to this RFP.



2. All prices quoted shall be in United States dollars.
3. Proposers are advised that in the evaluation of cost, if applicable, it will be assumed that the unit price quoted is correct in the case of a discrepancy between the unit price and extended price.

#### D. PROTESTS

Protests must be in writing and received no later than seven (7) business days after the Authority issues the Notice of Intent to Award, which is sent by electronic mail to all entities who submitted a proposal. The Authority will reject the protest as untimely if it is received after this specified time frame. Protests will be accepted from proposers or potential proposers only.

If the protest is mailed and not received by the Authority, the protesting party bears the burden of proof to submit documentation (e.g., certified mail receipt) that the protest was timely sent to be otherwise received by Authority within the RFP protest period.

Bid protests must contain a detailed and complete written statement describing the reason(s) for protest. The protest must include the RFP title and number, the name of the firm protesting, and include a name, telephone number, email address and physical address of the protestor. If a firm is representing the protestor, they shall include their contact information in addition to that of the protesting firm.

Protests must be mailed or hand delivered to UMRWA Secretary, 15083 Camanche Parkway South, Valley Springs, CA 95252. Facsimile and electronic mail protests must be followed by a mailed or hand delivered identical copy of the protest and must arrive within the seven-day time limit.

The Authority Executive Officer (EO), in consultation with Authority Counsel, will investigate the protest and if determined to be valid the EO may reject and re-bid or not re-bid the work, or recommend award to the remaining best qualified proposer. Affected proposers will be notified by electronic mail within 7 business days of the action taken.

The bid protestor can appeal the EO's determination to the UMRWA Board of Directors. The appeal must be submitted to the Authority Secretary no later than five working days from the date of receipt of the EO's determination on the initial protest.

Such an appeal must be made in writing and must include all grounds for the appeal and copies of the original protest and the Authority's response. The appeal will be scheduled for the next Board of Director's special or regular meeting. The Authority Secretary will advise the protestor of the date, time, and location of the Board of Directors meeting at which staff will make a recommendation for award and inform the protestor it may request to address the Board of Directors at that meeting.

The Authority may transmit copies of the protest and any attached documentation to all other parties who may be affected by the outcome of the protest. The decision of the Authority as to

the validity of any protest is final. This Authority's final decision will be transmitted to all affected parties in a timely manner.

**E. INVOICING**

1. Payment shall be made within thirty-(30) days following receipt of a correct invoice and upon complete satisfactory receipt of product and/or performance of services.
2. Invoices shall be submitted monthly during project operations.
3. The Authority shall notify General Service Provider of any invoice adjustments required.
4. Invoices shall contain, at a minimum, Authority RFP number, invoice number, remit to address, and itemized services description.
5. The Authority will pay General Service Provider in an amount not to exceed the negotiated amount(s) which will be referenced in the agreement signed by both parties.
6. Prior to making any payment, the Authority may require Contractor to furnish lien releases conforming to the requirements of California Civil Code section 8120, et seq., receipts or other evidence of payment from all persons performing work and supplying material to Contractor.
7. Contractor shall be required to make cash deposits for included timber and required deposits in advance of cutting and within 30 days of invoicing by UMRWA. These deposits shall be in cash in a form specified by UMRWA. Advanced deposits will be in such amounts as to maintain an unobligated balance sufficient enough to cover the value of timber to be cut. Contractor and UMRWA will agree on a systematic approach to provide sufficient advanced deposits.

**IV. RFP RESPONSE SUBMITTAL INSTRUCTIONS AND INFORMATION**

**A. AUTHORITY CONTACTS**

All contact during the competitive process is to be through the contact person listed on the first page of this RFP.

**B. SUBMITTAL OF RFP RESPONSE**

1. Late and/or unsealed responses will not be accepted.
2. RFP responses submitted via electronic transmissions will not be accepted. Electronic transmissions include faxed RFP responses or those sent by electronic mail ("e-mail").
3. RFP responses will be received only at the address shown below, must be SEALED, and must be received at the specified address by 4:00 p.m. on the due date specified in the Calendar of Events. Any RFP response received after that time or date, or at a place

other than the stated address cannot be considered and will be returned to the Proposer unopened. All RFP responses must be received and time stamped at the stated address by the time designated. The Authority's timestamp shall be considered the official timepiece for the purpose of establishing the actual receipt of RFP responses.

4. RFP responses are to be addressed/delivered as follows:

Mailed:

UMRWA  
15083 Camanche Parkway South  
Valley Springs, CA 95252

Hand Delivered or delivered by courier or package delivery service:

Same as above

Proposer's name, return address, and the RFP number and title must also appear on the mailing package.

5. Proposers are to submit one (1) original hardcopy RFP response (Exhibit A – RFP Response Packet, including all additional documentation stated in the “Required Documentation and Submittals” section of Exhibit A), all with original ink signatures.

Proposers **must** also submit an electronic copy of their RFP response, with their hardcopy RFP response Package. The file must be on a disk or USB flash drive and enclosed with the sealed original hardcopy of the RFP response. The electronic copy must be in a single file (PDF) format, and shall be an **exact** scanned image of the original hard copy Exhibit A – RFP Response Packet, and all additional documentation stated in the “Required Documentation and Submittals” section of Exhibit A.

6. All costs required for the preparation and submission of an RFP response shall be borne by the Proposer.
7. Proposer expressly acknowledges that it is aware that if a false claim is knowingly submitted (as the terms “claim” and “knowingly” are defined in the California False Claims Act, Cal. Gov. Code, §12650 et seq.), the Authority will be entitled to civil remedies set forth in the California False Claim Act.
8. The RFP response shall remain open to acceptance and is irrevocable for a period of 90 days, unless otherwise specified in the RFP documents.
9. It is understood that the Authority reserves the right to reject any or all RFP responses.

#### C. RESPONSE FORMAT

1. **Proposers shall not modify any part of Exhibits A, B, or C, or qualify their RFP responses. Proposers shall not submit to the Authority a re-typed or otherwise re-created version of these documents or any other Authority-provided document.**

2. RFP responses, in whole or in part, are NOT to be marked confidential or proprietary. The Authority may refuse to consider any RFP response or part thereof so marked. RFP responses submitted in response to this RFP may be subject to public disclosure. The Authority shall not be liable in any way for disclosure of any such records.

**EXHIBIT A  
RFP RESPONSE PACKET**

**RFP No. 18 - 04: Cabbage Patch Thinning and Mastication**

To: Upper Mokelumne River Watershed Authority (“Authority”)

From: \_\_\_\_\_  
(Name and Official Title of Proposer)

Preferred electronic mail (email) address: \_\_\_\_\_

**RFP RESPONSE PACKET GUIDELINES**

- **AS DESCRIBED IN SECTION IV- RFP RESPONSE SUBMITTAL INSTRUCTIONS AND INFORMATION, PROPOSERS ARE TO SUBMIT ONE (1) ORIGINAL HARDCOPY RFP RESPONSE WITH ORIGINAL INK SIGNATURES, ONE COPY, AND ONE (1) ELECTRONIC COPY (in PDF format and on a CD or flash drive) CONTAINING THE FOLLOWING, IN THEIR ENTIRETY:**
  - **EXHIBIT A – RFP RESPONSE PACKET, INCLUDING ALL ADDITIONAL REQUIRED DOCUMENTATION AS DESCRIBED IN EXHIBIT A- REQUIRED DOCUMENTATION AND SUBMITTALS**
  
- **PROPOSERS THAT DO NOT COMPLY WITH THE REQUIREMENTS, AND/OR SUBMIT AN INCOMPLETE RFP RESPONSE MAY BE SUBJECT TO DISQUALIFICATION AND THEIR RFP RESPONSE REJECTED IN TOTAL.**
  
- **IF PROPOSERS ARE MAKING ANY CLARIFICATIONS AND/OR AMENDMENTS, OR TAKING EXCEPTION TO ANY PART OF THIS RFP, THESE MUST BE SUBMITTED IN THE EXCEPTIONS, CLARIFICATIONS, AND AMENDMENTS SECTION OF THIS EXHIBIT A – RFP RESPONSE PACKET. THE AUTHORITY, AT ITS SOLE DISCRETION, MAY ACCEPT AMENDMENTS/EXCEPTIONS, OR MAY DEEM THEM TO BE UNACCEPTABLE, THEREBY RENDERING THE RFP RESPONSE DISQUALIFIED.**

## PROPOSER INFORMATION AND ACCEPTANCE

1. The undersigned declares that all RFP documents, including, without limitation, the RFP, Addenda, and Exhibits, have been read and that the terms, conditions, certifications, and requirements are agreed to.
2. The undersigned is authorized to offer, and agrees to furnish, the articles and services specified in accordance with the RFP documents of RFP No. 17-01.
3. The undersigned acknowledges acceptance of all addenda related to this RFP. List Addenda for this RFP on the line below:

Addendum #	Date

4. The undersigned hereby certifies to the Authority that all representations, certifications, and statements made by the Proposer, as set forth in this RFP Response Packet and attachments, are true and correct and are made under penalty of perjury pursuant to the laws of California.
5. The undersigned acknowledges that the Proposer is, and will be, in good standing in the State of California, with all the necessary licenses, permits, certifications, approvals, and authorizations necessary to perform all obligations in connection with this RFP and associated RFP documents.
6. It is the responsibility of each Proposer to be familiar with all of the specifications, terms, and conditions, and the site condition. By the submission of an RFP response, the Proposer certifies that if awarded a contract it will make no claim against the Authority based upon ignorance of conditions or misunderstanding of the specifications.
7. Patent indemnity: General or Professional Service Providers who do business with the Authority shall hold the Authority, its Directors, officers, agents, and employees harmless from liability of any nature or kind, including cost and expenses, for infringement or use of any patent, copyright or other proprietary right, secret process, patented or unpatented invention, article, or appliance furnished or used in connection with the contract or purchase order.
8. Insurance certificates are not required at the time of submission. However, by signing Exhibit A – RFP Response Packet, the Proposer agrees to meet the minimum insurance requirements stated in the RFP. This documentation must be provided to the Authority prior to execution of an agreement by the Authority, and shall include an insurance certificate which meets the minimum insurance requirements, as stated in the RFP.
9. The undersigned Proposer hereby submits this RFP response and binds itself to the Authority. The RFP, subsequent Addenda, Proposers Response Packet, and any attachments, shall be used to form the basis of a Contract, which once executed shall take precedence.

Official Name of Proposer (exactly as it appears on Proposer's corporate seal and invoice): \_\_\_\_\_

Street Address Line 1: \_\_\_\_\_

Street Address Line 2: \_\_\_\_\_

City: \_\_\_\_\_ State: \_\_\_\_\_ Zip Code: \_\_\_\_\_

Webpage: \_\_\_\_\_

Type of Entity / Organizational Structure (check one):

- |  |  |
|--|--|
| <input type="checkbox"/> Corporation                   | <input type="checkbox"/> Joint Venture       |
| <input type="checkbox"/> Limited Liability Partnership | <input type="checkbox"/> Partnership         |
| <input type="checkbox"/> Limited Liability Corporation | <input type="checkbox"/> Non-Profit / Church |
| <input type="checkbox"/> Other: _____                  |  |

Jurisdiction of Organization Structure: \_\_\_\_\_

Date of Organization Structure: \_\_\_\_\_

Federal Tax Identification Number: \_\_\_\_\_

Primary Contact Information:

Name / Title: \_\_\_\_\_

Telephone Number: \_\_\_\_\_ Fax Number: \_\_\_\_\_

E-mail Address: \_\_\_\_\_

Street Address Line 1: \_\_\_\_\_

City: \_\_\_\_\_ State: \_\_\_\_\_ Zip Code: \_\_\_\_\_

**SIGNATURE:** \_\_\_\_\_

Name and Title of Signer (printed): \_\_\_\_\_

Dated this \_\_\_\_\_ day of \_\_\_\_\_ 20\_\_\_\_\_

## PROPOSAL

Cost shall be submitted on this Proposal Form as is. The prices quoted shall not include Sales Tax or Use Tax; said tax, wherever applicable, will be paid by the Authority to the General or Professional Service Provider, if licensed to collect, or otherwise directly to the State.

No alterations or changes of any kind to the Proposal Form(s) are permitted. RFP responses that do not comply may be subject to rejection in total. The cost quoted below shall be the cost the Authority will pay for the term of any contract that is a result of this RFP process.

**Quantities listed herein are an estimated quantity based on Forest Service measurements and are not to be construed as guarantees. No minimum or maximum is guaranteed or implied.**

### Thinning and Mastication

Description	Unit of Measure	Estimated Quantity	Unit Cost	Extended Cost
Item 1. Thinning and Mastication	acre	132.3	\$	\$
<b>TOTAL COST</b>				\$



**All the specific documentation listed below is required to be submitted with the Exhibit A – RFP Response Packet and will become attached to and become a binding part of the final contract. Proposers shall submit all documentation, in the order listed below, and clearly label each section of the RFP response with the appropriate title (i.e. Table of Contents, Approach, etc.).**

**1) Approach and Technical Criteria:**

- a) **Approach:** RFP response shall demonstrate a thorough understanding of the purpose and scope of the project. Identify and describe planning for mitigation of schedule risks that the Proposer believes may adversely affect any portion of the Authority's schedule such as accounting for fire danger shutdowns, weather, or imposed contractual wildlife limitations.
- b) **Schedule:** RFP response shall describe Proposer's implementation plan and schedule in order to meet the Authority's schedule based on the daily production and capacity needed to complete the project and fulfill all contractual obligations by the termination date.
- c) **Fire Prevention:** RFP response shall describe fire prevention approach and whether Proposers' woods employees received the requisite firefighter training necessary to take action in the event of an operations fire, using the fire preventive equipment required in Exhibit C, Fire Precautions and Control.
- d) **Equipment:** RFP response shall describe the equipment to be used to accomplish the specified and prescriptive work as described in this RFP solicitation. List the type of equipment the Proposer will use to meet the contractual specifications.

**2) Relevant Experience:**

- a) **Proposer Experience:** RFP response shall describe the Proposer's prior experience with similar projects and comparable work. Describe whether the Proposer worked on USFS lands and completed projects on time. Describe the Proposer's process to coordinate with field personnel to address operational questions and related issues in a timely fashion.
- b) **Key Personnel and Quality Control Plan:** RFP response shall describe to what extent the individuals and Field Supervisor assigned to the project have experience on similar projects and how extensive their experience is in applying complex forestry silvicultural prescriptions, such as designation by description or prescription. List their names and relevant experience.

**3) References:** The RFP response shall include a description of relevant experience of Proposer's key personnel who will be working on this contract. References **MUST** demonstrate the successful completion of similar projects in similar vegetation and terrain as that which is described in this RFP.

- a) Proposers must use the templates in the "References" section of this Exhibit A – RFP Response Packet to provide references.
- b) References should have similar scope, volume, and requirements to those outlined in these specifications, terms, and conditions.
  - (1) Proposers must verify the contact information for all references provided is current and valid.

- (2) Proposers are strongly encouraged to notify all references that the Authority may be contacting them to obtain a reference.
- c) The Authority may contact some or all of the references provided in order to determine Proposer's performance record on work similar to that described in this RFP. The Authority reserves the right to contact references other than those provided in the RFP response and to use the information gained from them in the evaluation process.

**4) Exceptions, Clarifications, Amendments:**

- a) The RFP response shall include a separate section calling out all clarifications, exceptions, amendments, and concerns with specifications affecting bid, if any, to the RFP and associated RFP documents, which shall be submitted with the proposer's RFP response using the template in the "Exceptions, Clarifications, Amendments" section of this Exhibit A – RFP Response Packet.
- b) THE AUTHORITY IS UNDER NO OBLIGATION TO ACCEPT ANY EXCEPTIONS, AND SUCH EXCEPTIONS MAY BE A BASIS FOR RFP RESPONSE DISQUALIFICATION.**

---

## DECLARATION OF LOCAL SERVICE PROVIDER

### RFP No. 18 - 04: Cabbage Patch Thinning and Mastication

The Upper Mokelumne River Watershed Authority (UMRWA) may give local business enterprises a preference when awarding general service agreements as set forth in UMRWA's Procurement Policy.

In order to qualify for consideration with this preference, a business enterprise must meet the following criteria:

- Where available, possess a valid business license issued from Amador, Calaveras or Alpine County or a political subdivision within these counties; and
- Its principal business office, or a satellite office from which the business enterprise operates or performs business on a day-to-day-basis, is physically located within Amador, Calaveras or Alpine County.

All information submitted is subject to investigation, as well as disclosure to third parties under the California Public Records Act. Incomplete, unclear, or incomprehensible responses to the following may result in the Proposer not being considered as a Local Service Provider under this policy.

1. Legal name of business: \_\_\_\_\_
2. Physical address of principal place of business or bona-fide satellite office (e.g. with daily operations; or at least one regular employee, etc.):  
\_\_\_\_\_  
\_\_\_\_\_
3. Business license, IF AVAILABLE, issued by City of \_\_\_\_\_, or County of \_\_\_\_\_.  
License Number: \_\_\_\_\_

Authorized Signature: \_\_\_\_\_

Date: \_\_\_\_\_

Printed Name & Title: \_\_\_\_\_

## REFERENCES

### RFP No. 18 - 04: Cabbage Patch Thinning and Mastication

**Proposer Name:** \_\_\_\_\_

**Proposer must provide a minimum of 3 references.**

Company Name:	Contact Person:
Address:	Telephone Number:
City, State, Zip:	E-mail Address:
Services Provided / Date(s) of Service:	

Company Name:	Contact Person:
Address:	Telephone Number:
City, State, Zip:	E-mail Address:
Services Provided / Date(s) of Service:	

Company Name:	Contact Person:
Address:	Telephone Number:
City, State, Zip:	E-mail Address:
Services Provided / Date(s) of Service:	

Company Name:	Contact Person:
Address:	Telephone Number:
City, State, Zip:	E-mail Address:
Services Provided / Date(s) of Service:	

Company Name:	Contact Person:
Address:	Telephone Number:
City, State, Zip:	E-mail Address:
Services Provided / Date(s) of Service:	



**EXHIBIT B**  
**INSURANCE REQUIREMENTS**  
**RFP No. 18 - 04: Cabbage Patch Thinning and Mastication**

Insurance certificates are not required at the time of submission; however, by signing Exhibit A – RFP Response Packet, the Proposer agrees to meet the minimum insurance requirements stated in the RFP. This documentation must be provided to the Authority, prior to award.

The following are the minimum insurance limits, required by the Authority, to be held by the GENERAL SERVICE PROVIDER performing on this RFP.

**INDEMNIFICATION AND INSURANCE**

A. Indemnification

GENERAL OR PROFESSIONAL SERVICE PROVIDER expressly agrees to defend, indemnify, and hold harmless the Authority and its Directors, officers, agents, and employees from and against any and all loss, liability, expense, claims, suits, and damages, including attorneys' fees, arising out of or resulting from GENERAL OR PROFESSIONAL SERVICE PROVIDER's, its associates', employees', subcontractors', or other agents' negligent acts, errors or omissions, or willful misconduct, in the operation and/or performance under this Agreement.

B. Insurance Requirements

GENERAL OR PROFESSIONAL SERVICE PROVIDER shall take out and maintain during the life of the Agreement all the insurance required in this section, and if requested shall submit certificates for review and approval by the Authority. The Notice to Proceed shall not be issued, and GENERAL OR PROFESSIONAL SERVICE PROVIDER shall not commence work until such insurance has been approved by the Authority. The certificates shall be on forms approved by the Authority. Acceptance of the certificates shall not relieve GENERAL OR PROFESSIONAL SERVICE PROVIDER of any of the insurance requirements, nor decrease the liability of GENERAL OR PROFESSIONAL SERVICE PROVIDER. The Authority reserves the right to require GENERAL OR PROFESSIONAL SERVICE PROVIDER to provide insurance policies for review by the Authority.

C. Workers Compensation Insurance

GENERAL OR PROFESSIONAL SERVICE PROVIDER shall take out and maintain during the life of the Agreement Workers Compensation Insurance for all of its employees on the project. In lieu of evidence of Workers Compensation Insurance, the Authority will accept a Self-Insured Certificate from the State of California. GENERAL OR PROFESSIONAL SERVICE PROVIDER shall require any subcontractor to provide it with evidence of Workers Compensation Insurance.

D. Commercial General Liability Insurance

GENERAL OR PROFESSIONAL SERVICE PROVIDER shall take out and maintain during the life of the Agreement Automobile and General Liability Insurance that provides protection from claims which may arise from operations or performance under this Agreement. If GENERAL OR

PROFESSIONAL SERVICE PROVIDER elects to self-insure (self-fund) any liability exposure during the contract period above \$50,000, GENERAL OR PROFESSIONAL SERVICE PROVIDER is required to notify the Authority immediately. Any request to self-insure must first be approved by the Authority before the changed terms are accepted. GENERAL OR PROFESSIONAL SERVICE PROVIDER shall require any subcontractor or Professional Service Provider to provide evidence of liability insurance coverages.

The amounts of insurance shall be not less than the following:

\$1,000,000/Occurrence, Bodily Injury, Property Damage -- Automobile.

\$1,000,000/Occurrence, Bodily Injury, Property Damage -- General Liability.

The following coverages or endorsements must be included in the policy(ies):

1. The Authority, its Directors, officers, and employees are Additional Insureds in the policy(ies) as to the work being performed under the contract.
2. The coverage is *Primary and non-contributory* to any other applicable insurance carried by the Authority.
3. The policy(ies) covers *contractual liability*.
4. The policy(ies) is written on an *occurrence* basis.
5. The policy(ies) covers the Authority's Property in Consultant's care, custody, and control.
6. The policy(ies) covers *personal injury* (libel, slander, and wrongful entry and eviction) liability.
7. The policy(ies) covers explosion, collapse, and underground hazards, fire suppression expense, property damage to forest land due to fire, and property damage to non-owned automobiles and equipment due to fire.
8. The policy(ies) covers *products and completed operations*.
9. The policy(ies) covers the use of *owned, non-owned*, and hired automobiles.
10. The policy(ies) and/or a separate pollution liability policy(ies) shall cover pollution liability for claims related to the release or the threatened release of pollutants into the environment arising out of or resulting from Consultant's performance under this agreement.
11. The policy(ies) will not be canceled nor the above coverages/endorsements reduced without 30 days written notice to Authority at the address above.

**EXHIBIT C**  
**GENERAL SERVICES AGREEMENT**  
**RFP No. 18 - 04: Cabbage Patch Thinning and Mastication**

**General Requirements**

**CONTENTS**

1. DEFINITIONS
2. CONTRACTOR'S FINANCIAL OBLIGATION
3. MATERIAL AND WORKMANSHIP
4. DEFECTIVE WORK
5. SAFETY AND ACCIDENT PREVENTION
6. CHARACTER OF WORKFORCE
7. PAYROLL RECORDS
8. HOURS OF LABOR
9. EMPLOYMENT OF APPRENTICES
10. CHANGES
11. EFFECT OF EXTENSIONS OF TIME
12. DELAYS
13. TERMINATION
14. DAMAGES
15. ORDER OF PRECEDENCE
16. INDEMNIFICATION/RESPONSIBILITY
17. PROHIBITION OF ASSIGNMENT
18. NEWS RELEASES
19. TRANSFER OF INTEREST
20. SEVERABILITY
21. COVENANT AGAINST GRATUITIES
22. RIGHTS AND REMEDIES OF THE AUTHORITY
23. WAIVER OF RIGHTS
24. CONFIDENTIALITY

**1. DEFINITIONS**

The following terms shall be given the meaning shown, unless context requires otherwise or a unique meaning is otherwise specified.

- a. **"Authority"** means the Upper Mokelumne River Watershed Authority, its employees acting within the scope of their authority, and its authorized representatives.
- b. **"Change Order"** A Change Order is a written instrument used for modifying the contract with regards to the scope of Work, contract sum, and/or Contract Time. An approved Change Order is a Change Order signed by the Authority. An executed Change Order is a Change Order signed by both the Authority and the Contractor.
- c. **"Contract"** means the agreement between the Authority and Contractor as memorialized in the Contract Documents.



- d. **“Business Entity”** means any individual, business, partnership, joint venture, corporation, sole proprietorship, or other private legal entity recognized by statute.
- e. **“Buyer”** means the Authority’s authorized contracting official.
- f. **“Contract Documents”** comprise the entire agreement between the Authority and the Contractor and can include the Authority’s contract form if used, any purchase order, RFP, RFQ or Contractor response packet, and any addenda, appendices and Authority approved changes or amendments. The Contract Documents are intended to be complementary and include all items necessary for the Contractor’s proper execution and completion of the Work. Any part of the Work not shown or mentioned in the Contract Documents that is reasonably implied, or is necessary or usual for proper performance of the Work, shall be provided by the Contractor at its expense.
- g. **“Contractor”** means the Business Entity with whom the Authority enters into a contractual agreement. Contractor shall be synonymous with “supplier”, “vendor”, “consultant” or other similar term.
- h. **“Day”** unless otherwise specified, days are calendar days, measured from midnight to the next midnight.
- i. **“Goods”** means off the shelf software and all types of tangible personal property, including but not limited to materials, supplies, and equipment.
- j. **“Project Manager”** shall be the Authority designated individual responsible for administering and interpreting the terms and conditions of the Contract Documents, for matters relating to the Contractor’s performance under the Contract with the Authority, and for liaison and coordination between the Authority and Contractor.
- k. **“Work”** means all labor, tasks, materials, supplies, and equipment required to properly fulfill the Contractor’s obligations as required in the Contract Documents.
- l. **“Work Day”** Unless otherwise specified, work day includes all days of the year except Saturdays, Sundays and Authority holidays.

## 2. **CONTRACTOR’S FINANCIAL OBLIGATION**

The Contractor shall promptly make payments to all persons supplying labor and materials used in the execution of the contract.

## 3. **MATERIAL AND WORKMANSHIP**

- a. All work shall be done and completed in a thorough, workmanlike manner, notwithstanding any omission from these specifications or the drawings, and it shall be the duty of the Contractor to call attention to apparent errors or omissions and request instructions before proceeding with the work. The Project Manager may, by appropriate instructions, correct errors and omissions, which instructions shall be binding upon the Contractor as though contained in the original Contract Documents.
- b. All work must be satisfactory to the Project Manager. Work not in accordance with the Contract Documents, in the opinion of the Project Manager, shall be made to conform.

## 4. **DEFECTIVE WORK**

The Contractor shall replace at its own expense any part of the work that has been improperly executed, as determined by the Project Manager. If Contractor refuses or neglects to replace such defective work,

it may be replaced by the Authority at the expense of the Contractor, and its sureties shall be liable therefore.

**5. SAFETY AND ACCIDENT PREVENTION**

In performing work under the Contract on Authority premises, Contractor shall conform to any specific safety requirements contained in the Contract or as required by law or regulation. Contractor shall take any additional precautions as the Authority may reasonably require for safety and accident prevention purposes. Any violation of such rules and requirements, unless promptly corrected, shall be grounds for termination of this Contract or Contractor's right to preclude in accordance with the default provisions of the Contract Documents.

**6. CHARACTER OF WORKFORCE**

The Contractor shall employ none but skilled competent qualified personnel to perform the Work, and shall maintain discipline and order in the conduct of the Work at all times.

**7. PAYROLL RECORDS**

- a. The Contractor and each Subcontractor shall keep an accurate payroll record, showing the name, address, social security number, work classification, straight time and overtime hours worked each day and week, and the actual per diem wages paid to each journeyman, apprentice, worker or other employee employed in connection with the Work. The payroll records shall be certified and shall be available for inspection in accordance with the provisions of Section 1776 of the Labor Code. Certified payroll records shall be on the forms provided by the DIR or contain the same information required on the Department's form.
- b. Upon request, the Contractor shall submit for each week in which any contract Work is performed a copy of all payroll records to the Project Manager. The Contractor shall be responsible for submission of copies of payroll records of all Subcontractors.
- c. The Contractor or Subcontractor shall certify the payroll records as shown on the DIR form. In addition, the records shall be accompanied by a statement signed by the Contractor or Subcontractor certifying that the classifications truly reflect the Work performed and that the wage rates are not less than those required to be paid.
- d. For public works projects awarded on or after April 1, 2015, or that are still ongoing after April 1, 2016, no matter when awarded, each Contractor and Subcontractor shall furnish the certified payroll related records as more specifically described above and in Labor Code section 1776 directly to the Labor Commissioner (see LC § 1771.4). These records shall be provided to the Labor Commissioner at least monthly or more frequently if required by the terms of the Contract. For exception on projects covered by collective bargaining agreements like a PLA, please see Labor Code section 1771.4.
- e. In the event of noncompliance with the requirements of Section 1776 of the Labor Code, the Contractor shall have 10 days in which to comply subsequent to receipt of written notice specifying in what respects such Contractor must comply with said Section. Should noncompliance still be evident after such 10-day period, the Contractor shall, as a penalty to the State or the Authority, forfeit the amount set forth in Section 1776 of the Labor Code for each calendar day, or portion thereof, for each worker, until strict compliance is effectuated. Upon the request of the Division of Apprenticeship Standards or the Division of Labor Standards Enforcement, such penalties shall be withheld from progress payments then due.
- f. The Contractor and every Subcontractor shall post at the workplace and comply with all

required wage related workplace postings. Copies of the required postings may be downloaded or ordered electronically from the Department of Industrial Relations website at <http://www.dir.ca.gov/wpnodb.html>.

## **8. HOURS OF LABOR**

Pursuant to the provisions of Sections 1810, et seq. of the Labor Code and any amendments thereof:

- a. Eight hours of labor constitutes a legal day's Work under the contract.
- b. The time of service of any worker employed upon the work shall be limited and restricted to eight hours during any one calendar day, and forty hours during any one calendar week except as provided in Article 13.iv below.
- c. The Contractor shall, as a penalty to the State or the Authority, forfeit the amount set forth in Section 1813 of the Labor Code for each worker employed in the execution of the contract by the Contractor or by any Subcontractor for each calendar day during which such worker is required or permitted to work more than eight hours in any calendar day and forty hours in any one calendar week in violation of this Article and the provisions of Labor Code, Sections 1810, et seq.
- d. Work performed by employees of the Contractor in excess of eight hours per day, and forty hours during any one calendar week, shall be permitted upon compensation for all hours worked in excess of eight hours per day at not less than one and one-half times the basic rate of pay.
- e. The Contractor and every Subcontractor shall keep an accurate record showing the name of and the actual hours worked each calendar day and each calendar week by each worker employed by him in connection with the Work; the record shall be kept open at all reasonable hours to the inspection of the Authority and to the Division of Labor Standards Enforcement of the State of California.

## **9. EMPLOYMENT OF APPRENTICES**

- a. In the performance of the contract, the Contractor and any Subcontractor shall comply with the provisions concerning the employment of apprentices in Section 1777.5 of the Labor Code and any amendments thereof.
- b. In the event the Contractor or any Subcontractor willfully fails to comply with the aforesaid section, such Contractor or Subcontractor shall be subject to the penalties for noncompliance in Labor Code, Section 1777.7.

## **10. CHANGES**

- a. Changes in the Work can only be made in writing signed by an authorized employee of the Authority. If the change causes an increase or decrease in the contract sum, or a change in the time for performance under the Contract, an adjustment may be made as determined by the Project Manager.
- b. The Authority reserves the right to make changes in the design of materials, equipment, or machinery, to make alterations or additions to or deviations or subtractions from the Contract and any specifications and drawings, to increase or decrease the required quantity of any item or portion of the Work or to omit any item or portion of the Work, as may be deemed by the Project Manager to be necessary or advisable and to order such extra work as may be

determined by the Project Manager to be required for the proper execution and completion of the whole Work contemplated. Any such changes will be ordered in writing by the Project Manager. The determination of the Project Manager on all questions relating to changes, including extra work, shall be conclusive and binding.

- c. Prior to issuing an amendment or change to the Contract, the Project Manager may request that the Contractor submit a proposal covering the changes. Within 10 business days of receiving the request, the Contractor shall submit its proposal to the Project Manager of all costs associated with the proposed amendment or change and any request for an extension of Contract time. Contractor's proposal shall include detailed estimates with cost breakdowns, including labor, material, equipment, overhead, and profit. Labor shall be broken down into hours and rate per hour. If applicable, the proposal shall include a breakdown for off-site labor (including factory labor, engineering, etc.). The Contractor's proposal shall include an analysis of schedule impact when the Contractor is requesting an adjustment in contract time. The Contractor shall be responsible for any delay associated with its failure to submit its change proposal within the time specified. If the Project Manager decides not to issue an amendment or change after requesting a proposal from the Contractor, the Contractor will be notified in writing. The Contractor is not entitled to reimbursement for Change Order preparation costs if the Contractor's proposal is not accepted by the Project Manager.
- d. If the Contractor agrees with the terms and conditions of the approved Change Order, the Contractor shall indicate its acceptance by signing the original copy and returning it to the Project Manager within 10 Work Days after receipt or with reasonable promptness and in such sequence as to not delay the Work or activities of the Authority or of separate contractors, whichever is sooner. If notice of any change is required to be given to a surety by the provisions of any bond, the Contractor shall provide notice and the amount of each applicable bond shall be adjusted separately. Payment in accordance with the terms and conditions set forth in the executed Change Order shall constitute full compensation for all Work included in the Change Order and the Authority will be released from any and all claims for direct, indirect, and impact expenses and additional time impact resulting from the Work. If the Contractor disagrees with the terms and conditions of the approved Change Order, the Contractor shall indicate specific areas of disagreement and return the approved Change Order to the Project Manager with a detailed written dispute. No payment will be made on the disputed work until the approved Change Order is returned to the Project Manager. However, whether or not the Contractor agrees with the terms and conditions of an approved Change Order, the Contractor shall immediately revise its sequence of operations as required to facilitate timely completion of the changed work and shall proceed with the revised work sequence.
- e. The Project Manager may, after having received a written cost quotation from the Contractor, order the Contractor, in writing, to proceed with the work prior to issuance of an approved Change Order through a change directive. The change directive will authorize the Contractor to proceed with the work subject to the cost quotation submitted by the Contractor. Within five days following receipt of the change directive, the Contractor shall submit a detailed change proposal documenting the amount of compensation. The Project Manager will review the change proposal and, at its option, will either issue an approved Change Order for the work or direct the Contractor to perform the work through Force Account. Until the method of compensation is determined and the approved Change Order is received, the Contractor shall keep full and complete time and material records of the cost of the ordered work and shall permit the Project Manager to have access to such records. An approved Change Order shall

supersede any previously issued written change directive covering the same Work.

#### **11. EFFECT OF EXTENSIONS OF TIME**

The granting, or acceptance, of extensions of time to complete the Work or furnish the labor, supplies, materials or equipment, or any one of the aforementioned, will not operate as a release of Contractor or the surety on Contractor's faithful performance bond.

#### **12. DELAYS**

- a. The Contractor shall take reasonable precautions to foresee and prevent delays to the Work. When the Contractor foresees a delay event, and upon the occurrence of a delay event, the Contractor shall immediately notify the Project Manager of the probability or the actual occurrence of a delay, and its cause. With respect to all delays (compensable, excusable or inexcusable), the Contractor shall reschedule the Work and revise its operations, to the extent possible, to mitigate the effects of the delay. Within 15 days from the beginning of a delay the Contractor shall provide the Project Manager with a detailed written description of the delay, its cause, its impact and the Contractor's mitigation plans. Failure to provide the notification required above waives the Contractor's right to any additional time or compensation resulting from the delay for whatever cause. The Project Manager will investigate the facts and ascertain the extent of the delay, and the Project Manager's findings thereon shall be final and conclusive, except in the case of gross error. An extension of time must be approved by the Project Manager to be effective, but an extension of time, whether with or without consent of the sureties, shall not release the sureties from their obligations, which shall remain in full force until the discharge of the contract.
- b. For inexcusable delays (delays caused by circumstances within the Contractor's control, the control of its subcontractors or supplies of any tier, or within the scope of the Contractor's contract responsibilities) the Contractor shall not be entitled to an extension of time or additional compensation for any loss, cost, damage, expense or liability resulting directly or indirectly from the inexcusable delay.
- c. For excusable delays (delays to completion of the Work within the time limits set forth in the Contract Documents directly caused by events beyond the control of both the Contractor and the Authority, which delay is not concurrent with an inexcusable delay and which could not have been avoided by the Contractor through reasonable mitigation measures).
- d. For compensable delays (delays to completion of the Work within the time limits set forth in the Contract Documents that could not be avoided by Contractor mitigation, caused directly and solely by the Authority or by causes within the exclusive control of the Authority, and which were not concurrent with any other type of delay) the Project Manager will grant the Contractor an extension of the time to perform under the Contract and compensation in an amount that represents the Contractor's actual direct costs incurred as a direct result of the compensable delay. The Contractor may recover its direct costs only and may not recover (and waives) all other types of indirect, consequential, special and incidental damages.
- e. For concurrent delays (two or more independent causes of delay directly preventing the Contractor from completing the Work within the time limits set forth in the Contract Documents where the delays occur at the same time during all or a portion of the delay period being considered, and where each of the delays would have caused delay to the Contractor even in the absence of any of the other delays, and none of the delays could have been avoided by Contractor mitigations) the following rules apply:

- i. One or more of the concurrent delays are excusable or compensable, then the period of concurrent delay will be treated as an excusable delay; and
- ii. All of the concurrent delays are inexcusable, then the period of concurrent delay will be inexcusable.

### 13. TERMINATION

#### a. Termination by the Authority for Cause:

- i. Authority may terminate the Contractor's right to proceed under the Contract, in whole or in part, for cause at any time after the occurrence of any of the following events, each of which constitutes a default:
  - 1. The Contractor becomes insolvent or files for relief under the bankruptcy laws of the United States.
  - 2. The Contractor makes a general assignment for the benefit of its creditors or fails to pay its debts as the same become due.
  - 3. A receiver is appointed to take charge of the Contractor's property.
  - 4. The Contractor fails to supply skilled supervisory personnel, an adequate number of properly skilled workers, proper materials, or necessary equipment to prosecute the Work in accordance with the Contract Documents.
  - 5. The Contractor fails to make progress so as to endanger performance of the Work within the contractually required time.
  - 6. The Contractor disregards legal requirements of agencies having jurisdiction over the Work, the Contractor, or the Authority.
  - 7. The Contractor fails to provide the Authority with a written plan to cure a Authority identified default within five business days after the Authority's request for a plan to cure; the Authority does not accept the Contractor's plan for curing its default; or the Contractor does not fully carry out an accepted plan to cure.
  - 8. The Contractor abandons the Work. Abandonment is conclusively presumed when the Authority requests a written plan to cure a default and the Contractor does not submit the plan within five business days of the Authority's request.
  - 9. The Contractor materially fails to meet its obligations in accordance with the Contract Documents.
  - 10. The Contractor is in default of any other material obligation under the Contract Documents.
- ii. If any of the above events occur, the Authority may, in its discretion, require that the Contractor submit a written plan to cure its default, which plan must be provided to the Authority within 5 business days of the request and must include a realistic, executable plan for curing the noted defaults.
- iii. Upon any of the occurrences referred to in Article 18.a.i. above, the Authority may, at its election and by notice to the Contractor, terminate the Contract in whole or in part; accept the assignment of any or all of the subcontracts; and then complete the Work by

any method the Authority may deem expedient. If requested by the Authority, the Contractor shall remove any part or all of the Contractor's materials, supplies, equipment, tools, and machinery from the site of the Work within seven days of such request; and, if the Contractor fails to do so, the Authority may remove or store, and after 90 days sell, any of the same at the Contractor's expense.

- iv. No termination or action taken by the Authority after termination shall prejudice any other rights or remedies of the Authority provided by law or by the Contract Documents.
- v. Conversion: If, after termination for other than convenience, it is determined that the Contractor was not in default or material breach, or that the default or material breach was excusable, the rights and obligations of the parties shall be the same as if the termination had been issued for convenience pursuant to Article 18.b. below.

b. Termination by the Authority for Convenience:

- i. The Authority may, at its option, and for its convenience, terminate the Contract at any time by giving written notice to the Contractor specifying the effective date of termination. Upon such termination, the Contractor agrees to comply with the notice and further agrees to waive any claims for damages, including loss of anticipated profits, on account of the termination; and, as the sole right and remedy of the Contractor, the Authority shall pay the Contractor as set forth below.
- ii. Upon receipt of a notice of termination for convenience, the Contractor shall, unless the notice directs otherwise, do the following:
  - 1. Immediately discontinue its performance of the Contract to the extent specified in the notice.
  - 2. Place no further orders or subcontracts for materials, equipment, services, or facilities, except as may be necessary for completion of a portion of the Work that is not discontinued or that is necessary for an orderly cessation of the Work.
  - 3. Promptly cancel, on the most favorable terms reasonably possible, all subcontracts to the extent they relate to the performance of the discontinued portion of the Work.
  - 4. Thereafter, do only such Work as may be necessary to preserve and protect Work already in progress and to protect materials, plants, and equipment in transit to or on the site of performance.
- iii. Upon such termination for convenience, the Authority will pay to the Contractor the sum of the following:
  - 1. The amount of the contract sum allocable to the portion of the Work properly performed by the Contractor as of the effective date of termination, less sums previously paid to the Contractor.
  - 2. Previously unpaid costs of any items delivered to the project site that were already fabricated for subsequent incorporation into the Work.
  - 3. Any proven losses with respect to materials and equipment directly resulting from the termination.

4. Reasonable demobilization costs.
- iv. The above reimbursement is the sole and exclusive remedy to which the Contractor is entitled in the event the contract is terminated for convenience; and the Contractor expressly waives any other claims, damages, demands, compensation or recovery related to this contract or project. The Contractor agrees to sign a general release incorporating this waiver.
- c. Effect of Termination: Upon termination, the obligations of the Contract shall continue as to portions of the Work already performed and, subject to the Contractor's obligations under Article 18.b.ii, as to bona fide obligations assumed by the Contractor prior to the date of termination.
- d. Force Majeure: If the contract is suspended or terminated by the Authority because Contractor's performance is prevented or delayed by an event including an irresistible, superhuman cause, or by the act of public enemies of the State of California or of the United States ("Force Majeure"), the Contractor will be paid for Work performed prior to the Force Majeure event at either (i) the unit prices named in the Contract; or (ii) in the event no unit prices are named, a sum equal to the percentage of the total contract amount that matches the percentage of the total contract Work performed prior to the Force Majeure event.

#### 14. DAMAGES

All losses or damages to material or equipment to be furnished pursuant to the Contract Documents occurring prior to receipt and final acceptance of the Work shall be sustained by the Contractor. The Contractor shall sustain all losses arising from unforeseen obstructions or difficulties, either natural or artificial, encountered in the prosecution of the Work, or from any action of the elements prior to final acceptance of the work, or from an act or omission on the part of the Contractor not authorized by the Contract Documents.

#### 15. ORDER OF PRECEDENCE

- a. In the case of conflicts, errors, or discrepancies in any of the Contract Documents, the order of precedence is as follows. Within the same order of precedence, specific requirements shall take precedence over general requirements.
  - i. Approved Change Orders.
  - ii. Addenda.
  - iii. RFQ or RFP.
  - iv. Referenced Standard Specifications and Drawings.
  - v. Contractor's Response Packet

#### 16. INDEMNIFICATION/RESPONSIBILITY

- a. Contractor shall indemnify, keep and save harmless the Authority and each of its directors, officers, agents and employees against any and all suits, claims or actions arising out of any of the following:
  - i. Any injury to persons or property that may occur, or that may be alleged to have occurred, arising from the performance or implementation of this Contract; or



- ii. Any allegation that materials or services developed, provided or used for this Contract infringe or violate any copyright, trademark, patent, trade secret, or any other intellectual-property or proprietary right of any third party.
- b. Contractor further agrees to defend any and all such actions, suits or claims and pay all charges of attorneys and all other costs and expenses of defenses as they are incurred. If any judgment is rendered, or settlement reached, against the Authority or any of the other agencies or individuals enumerated above in any such action, Contractor shall, at its expense, satisfy and discharge the same.
- c. This indemnification shall survive termination or expiration of the Contract.

**17. PROHIBITION OF ASSIGNMENT**

The Contractor shall not assign, transfer, or otherwise dispose of any of its rights, duties or obligations under this Contract.

**18. NEWS RELEASES**

The Contractor, its employees, subcontractors, and agents shall not refer to the Authority, or use any logos, images, or photographs of the Authority for any commercial purpose, including, but not limited to, advertising, promotion, or public relations, without the Authority's prior written consent. Such written consent shall not be required for the inclusion of the Authority's name on a customer list.

**19. TRANSFER OF INTEREST**

Contractor shall not assign, transfer or otherwise substitute its interest in the Contract or any of the contract obligations without prior written consent from the Authority.

**20. SEVERABILITY**

Should any part of the Contract be declared by a final decision by a court or tribunal of competent jurisdiction to be unconstitutional, invalid or beyond the authority of either party to enter into or carry out, such decision shall not affect the validity of the remainder of the Contract, which shall continue in full force and effect, provided that the remainder of the Contract can be interpreted to give effect to the intentions of the parties.

**21. COVENANT AGAINST GRATUITIES**

The Contractor warrants that no gratuities (in the form of entertainment, gifts, or otherwise) were offered or given by the Contractor, or any agent or representative of the Contractor, to any officer or employee of the Authority with a view toward securing the Contract or securing favorable treatment with respect to any determinations concerning the performance of the Contract. For breach or violation of this warranty, the Authority shall have the right to terminate the Contract, either in whole or in part, and any loss or damage sustained by the Authority in procuring on the open market any items which Contractor agreed to supply shall be borne and paid for by the Contractor. The rights and remedies of the Authority provided in this clause shall not be exclusive and are in addition to any other rights and remedies provided by law or in equity.

**22. RIGHTS AND REMEDIES OF THE AUTHORITY**

The rights and remedies of the Authority provided herein shall not be exclusive and are in addition to any other rights and remedies provided by law or under the Contract.

**23. WAIVER OF RIGHTS**

Any action or inaction by the Authority or the failure of the Authority on any occasion, to enforce any right or provision of the Contract, shall not be construed to be a waiver by the Authority of its rights and shall not prevent the Authority from enforcing such provision or right on any future occasion. Rights and

remedies are cumulative and are in addition to any other rights or remedies that the Authority may have at law or in equity.

**24. CONFIDENTIALITY**

Contractor agrees to maintain in confidence and not disclose to any person or entity, without the Authority's prior written consent, any trade secret or confidential information, knowledge or data relating to the products, process, or operation of the Authority. Contractor further agrees to maintain in confidence and not to disclose to any person or entity, any data, information, technology, or material developed or obtained by Contractor during the term of the Contract. The covenants contained in this paragraph shall survive the termination of this Contract for whatever cause.

**EXHIBIT C**  
**GENERAL SERVICES AGREEMENT**  
**RFP No. 18 - 04: Cabbage Patch Thinning and Mastication**

**Specifications For Operations**

Project units are listed in the table below and included on the Project Map.

<b>Item</b>	<b>Treatment Unit Number</b>	<b>Acres</b>
<b>Item 1. Thinning and Mastication</b>	157	19.4
	97	16.9
	105	3.2
	160	25.4
	154	3.4
	156	2.1
	185	8.5
	183	8.4
	182	27.2
	180	5.1
	181	5.2
	166	4.3
	170	3.2
<b>Total</b>		<b>132.2</b>

The following Specifications for Operations apply to activities under this Contract.

1. **Project Map (Map).** This is the boundary of the Treatment Units as shown on the Map and designated on the ground by the Forest Service. The following are identified on the Map as applicable:
  - a) Identified patented claims.
  - b) Boundaries of all stewardship treatment units.
  - c) Areas where leave trees are marked to be left uncut.
  - d) Roads where use is prohibited or restricted.
  - e) Roads and trails to be kept open.
  - f) Improvements to be protected.
  - g) Locations of known wildlife or plant habitat and cave resources to be protected.
  - h) Locations of areas known to be infested with specific invasive species of concern.
  - i) Streamcourses to be protected.
  - j) Locations of meadows requiring protection.
  - k) Locations of wetlands requiring protection.
  
2. **Control of Operations.** Under this Contract, "Contractor's Operations" shall include activities of or use of equipment of the Contractor, the Contractor's employees, agents, subcontractors, or their employees or agents, acting in the course of their employment in operations hereunder on national forest lands or

within U.S. Forest Service protection boundary (unless acting under the immediate supervision of U.S. Forest Service).

Contractor's Operations shall be conducted in a workmanlike and orderly manner. The timing of any required UMRWA designation of work on the ground and the performance of other U.S. Forest Service work shall not be such as to cause unnecessary delay to Contractor.

3. **Project Operations Schedule.** Contractor shall schedule and conduct operations so that they do not conflict with operations being conducted under existing contracts within the Project Area. Contractor shall reach agreement on operations with other contractors or adjust operations to eliminate the conflict.
4. **Wildlife Restrictions.** All units that fall within wildlife restrictions as designated on the Contract Area Map:
  - a) Controlled Area CA3: No Operations between March 1 and August 15, inclusive.
  - b) Controlled Area CA4: No Operations between February 15 and September 15, inclusive.
5. **Use of Roads by the Contractor.** Contractor is/are authorized to use existing National Forest system roads when such use will not cause damage to the roads or National Forest resources. UMRWA and the Forest Service will determine if such use will not cause damage to the roads or National Forest resources.
6. **Snow Removal.** If Contractor removes snow from roads, such work shall be done with UMRWA approval and in a manner that will protect roads and adjacent resources.

Snow berms shall be removed or placed to avoid accumulation of melt water on the road and prevent water concentration on erosive slopes or soils.

Snow must not be removed to the road surface. A minimum 6 inch snow depth must be left to protect roadway. If the road surface is damaged, Contractor shall replace lost surface material and repair structures damaged in blading operations.
7. **Protection of Residual Trees.** Contractor's operations shall not unnecessarily damage young growth or other trees to be reserved.
8. **Safety.** Contractor's operations shall facilitate UMRWA's safe and practical inspection of Contractor's operations and conduct of other official duties on the Project Area. Contractor has/have all responsibility for compliance with safety requirements for Contractor's employees.

When operations are in progress adjacent or on Forest Service controlled roads and trails open to public travel, Contractor shall furnish, install, and maintain all temporary traffic controls that provide the user with adequate warning of hazardous or potentially hazardous conditions associated with operations occurring in the area. The parties shall agree to a specific traffic control plan prior to commencement of work. Devices shall be appropriate to current conditions and shall be covered or removed when not needed.

During periods of general recreation activity within Project Area or vicinity, UMRWA may restrict road construction, timber cutting, yarding, and other harvesting operations to days other than Saturdays, Sundays, and holidays.

## PROJECT OPERATIONS SIGNING STANDARDS

All signs must be manufactured & installed as specified in the FHWA "**Manual on Uniform Traffic Control Devices**" (MUTCD) & FS publication "**Standards for Forest Service Signs & Posters**"( EM 7100-15).

### SIGN STANDARDS

**SHAPE & COLOR:** Generally, signs for logging and maintenance operations are either diamond-shaped or rectangular. All signs are **reflective orange background with black legend and border** unless shown otherwise. Handpainted, homemade signs are not legal. Fluorescent paint is not reflectorized.

**SUBSTRATE:** Sign substrate material may be High Density Overlay (HDO) Plywood, Aluminum, Fiberglass Reinforced Plastic, Corrugated Plastic or Roll-up Fabrics.

**SIGN SIZE:** Sign size is a factor of speed and MUTCD & FS standards. Where conditions of speed, volume, or special hazard require greater visibility or emphasis, larger signs should be used. Minimum sizes for the most common signs can be found in Figure 4. Refer to the EM-7100-15 for additional sign sizes.

**LEGEND:** All lettering shall be Series "C" alphabet, conforming to Standard Alphabets for Highway Signs. Letter size is also a function of speed - use letter size and word messages as specified in MUTCD and EM-7100-15.

### SIGN PLACEMENT

Signs are to be installed in locations as agreed to in the traffic control plan. All signs are to be removed, covered, or folded when operations are not in progress or the sign message is not applicable. Signs should generally be located on the right-hand side of the roadway. When special emphasis is needed, signs may be placed on both the left and right sides of the road. Sign message shall be clearly visible to road users, mounted on posts or portable sign stands.

#### **LATERAL CLEARANCE**

From the edge of the road - 2 foot minimum, where slope limits to less than 6 feet. 6-12 foot preferred.

#### **HEIGHT**

Minimum of 7 feet, measured from the bottom of the sign to the near edge of the travelway. The height to the bottom of a supplemental sign mounted below the primary sign will be 6 feet.

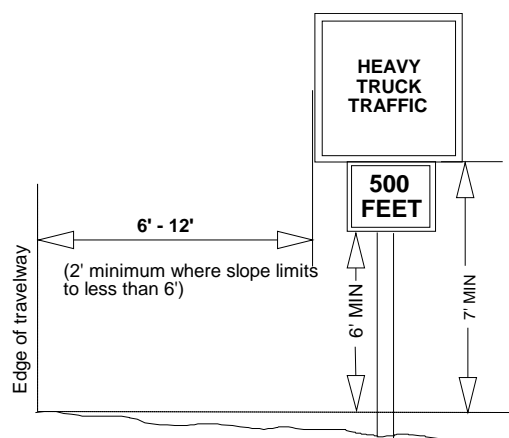

Figure 1: Sign Placement Dimensions

**PLACEMENT DISTANCE**

Signs must be located 100-500 feet prior to the activity, (both ends if a through road) and maintained at that distance. This distance is based on speed. Refer to Figure 2 , Table II-1, MUTCD, a portion of which is reproduced here, to determine correct placement distance.

Posted or 85 percentile speed MPH	Deceleration to listed advisory speed MPH				
	10	20	30	40	50
20	NA				
25	100				
30	150	100			
35	200	175			
40	275	250	175		
45	350	300	250		
50	425	400	325	225	
55	500	475	400	300	
60	575	550	500	400	300
65	650	625	575	500	375

Figure 2: A Portion of MUTCD TABLE II-1

**SIGN SUPPORTS**

**POSTS:** Signs are to be mounted on separate posts. Supplemental signs such as Speed Advisory plates are to be mounted on the same post as the primary sign. **Do not mount signs on trees or other signs.** Posts may be wood, metal, carsonite or similar material. Where sign supports cannot be sufficiently offset from the road edge, supports will meet breakaway standards. Single wood posts with less than 24 square inches do not require breakaway design.

**TEMPORARY/PORTABLE SUPPORTS:** Portable supports may be used for short-term, short-duration, and mobile conditions. MUTCD defines this time period as one work shift, 12 hours or less. All portable supports must meet MUTCD standards, including breakaway. These must be a minimum of 1 foot above the road surface or more if visibility requires it.

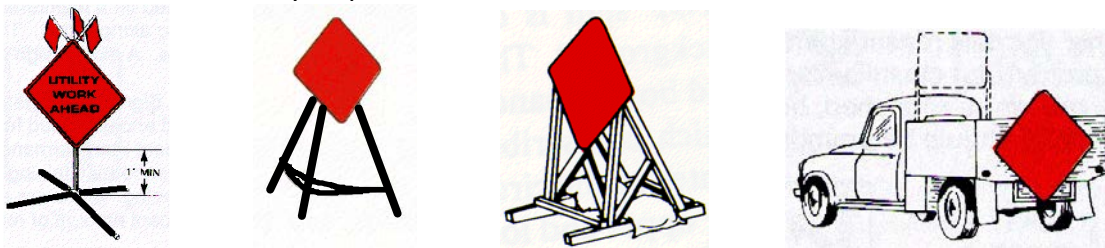
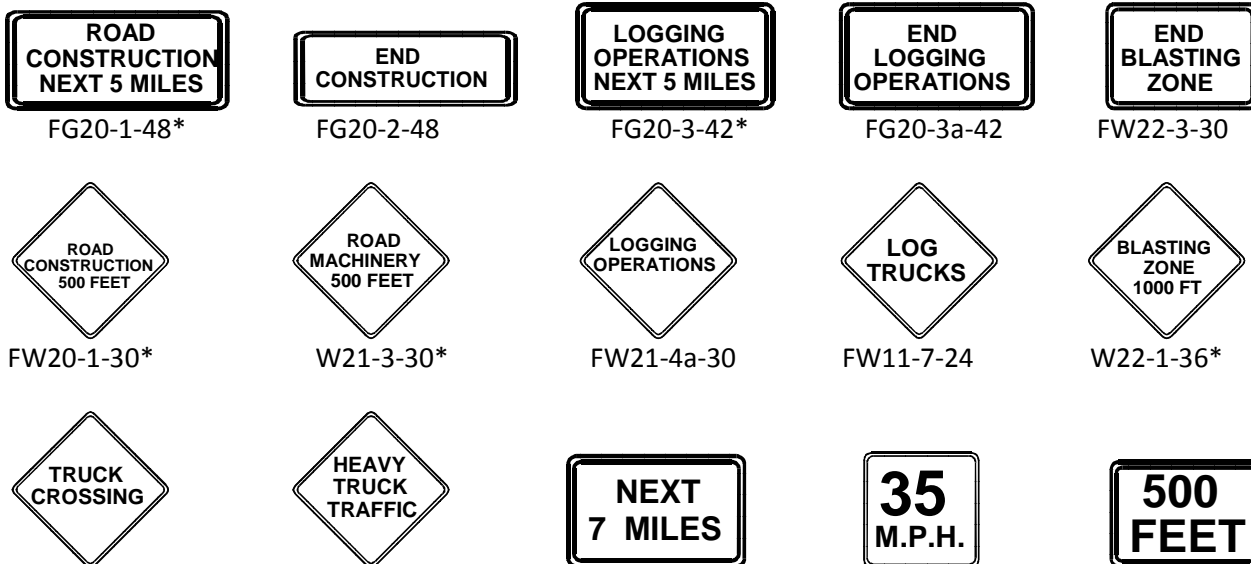

Figure 3: Examples of Temporary/Portable Supports

**SIGNS**

The following signs meet the intent of the Safety standard. *This is not a complete listing of signs that may be needed.*



FW8-6-24

FW11-9a-24

W7-3a-24\*

W13-1-18\*\*

W20-7aP-24\*

\* Specify Distance

\*\* Specify Speed



BM-L-O



BM-R-O

Barricade Markers (See MUTCD for length and stripe size)

9. **Accident and Injury Notification.** Contractor shall notify UMRWA of any lost time personal injury accident or any accident or vandalism resulting in personal property damage over \$400 in value that occurs as a result of or is associated with Contractor's Operations.

Contractor shall notify UMRWA within 8 hours of any personal injury accident. For vandalism and personal property accidents, Contractor shall notify UMRWA at the same time notification is given to the state and local law enforcement authorities.

Contractor shall take all reasonable measures after an accident or vandalism event to preserve the scene of the incident and provide information to facilitate a Forest Service investigation.

10. **Sanitation and Servicing.** Contractor shall take all reasonable precautions to prevent pollution of air, soil, and water by Contractor's operations. Precautions shall include if facilities for employees are established on the Project Area, they shall be operated in a sanitary manner. The parties shall agree to the cleanup and restoration of a polluted site. Contractor shall maintain all equipment operating on Project Area in good repair and free of abnormal leakage of lubricants, fuel, coolants, and hydraulic fluid. Contractor shall not service tractors, trucks, or other equipment on National Forest lands where servicing is likely to result in pollution to soil or water. Contractor shall furnish oil-absorbing mats for use under all stationary equipment or equipment being serviced to prevent leaking or spilled petroleum-based products from contaminating soil and water resources. Contractor shall remove from National Forest lands all contaminated soil, vegetation, debris, vehicle oil filters (drained of free-flowing oil), batteries, oily rags, and waste oil resulting from use, servicing, repair, or abandonment of equipment.
11. **Prevention of Oil Spills.** If Contractor maintain(s) storage facilities for oil or oil products on the Project Area, Contractor shall take appropriate preventive measures to ensure that any spill of such oil or oil products does not enter any stream or other waters of the United States or any of the individual States. If the total oil or oil products storage exceeds 1,320 gallons in containers of 55 gallons or greater, Contractor shall prepare a Spill Prevention Control and Countermeasures Plan. Such plan shall meet applicable EPA requirements (40 CFR 112), including certification by a registered professional engineer. Contractor shall notify the UMRWA and appropriate agencies of all reportable (40 CFR 110) spills of oil or oil products on or in the vicinity of the Project Area that are caused by Contractor's employees, agents, contractors or their employees or agents, directly or indirectly, as a result of Contractor's operations. Contractor will take whatever initial action may be safely accomplished to contain all spills.
12. **Hazardous Substances.** Contractor shall notify the National Response Center, UMRWA, and Forest Service principal contact of all releases of reportable quantities of hazardous substances on or in the

vicinity of the Project Area that are caused by Contractor's employees, agents, contractors or their employees or agents, directly or indirectly, as a result of Contractor's operations, in accordance with 40 CFR 302.

13. **Washing Equipment.** In order to prevent the spread of noxious weeds into the Project Area, Contractor shall be required to clean all off-road equipment **prior** to entry on to the Project Area. This cleaning shall remove all soil, plant parts, seeds, vegetative matter, or other debris that could contain or hold seeds. Only equipment so cleaned and inspected by UMRWA will be allowed to operate within the Project Area. All subsequent move-ins of equipment to the Project Area shall be treated in the same manner as the initial move in. "Equipment" includes all logging, mastication, and construction machinery, except for log trucks, chip vans, service vehicles, water trucks, pickup trucks, cars, and similar vehicles.

Contractor shall employ whatever cleaning methods are necessary to ensure that off-road equipment is free of noxious weeds. Equipment shall be considered free of soil, seed, and other such debris when a visual inspection does not disclose such material. Disassembly of equipment components or specialized inspection tools is not required.

As agreed upon, UMRWA shall inspect equipment at cleaning location.

New infestations of noxious weeds, of concern to Forest Service and identified by either UMRWA or Contractor, on the Project Area or on the haul route, shall be promptly reported to the other party. Contractor and UMRWA shall agree on treatment methods to reduce or stop the spread of noxious weeds when new infestations are found. A current list of noxious weeds of concern to Forest Service is available at each Forest Service office.

14. **Protection of Streamcourses.** Contractor's Operations shall be conducted to prevent debris from entering streamcourses, except as may be authorized under paragraph (d). In event Contractor cause(s) debris to enter streamcourses in amounts that may adversely affect the natural flow of the stream, water quality, or fishery resource, Contractor shall remove such debris as soon as practicable, but not to exceed 2 days, and in an agreed manner that will cause the least disturbance to streamcourses.
- a) Culverts or bridges shall be required on Temporary Roads at all points where it is necessary to cross Streamcourses. Such facilities shall be of sufficient size and design and installed in a manner to provide unobstructed flow of water and to minimize damage to streamcourses. Trees or products shall not be otherwise hauled or yarded across streamcourses unless fully suspended.
  - b) Wheeled or track-laying equipment shall not be operated in streamcourses, except at crossings agreed to by Contractor and UMRWA or as essential to construction or removal of culverts and bridges.
  - c) Flow in streamcourses may be temporarily diverted only if such diversion is necessary for Contractor's planned construction and UMRWA gives written authorization. Such flow shall be restored to the natural course as soon as practicable and, in any event, prior to a major storm runoff period or runoff season.
15. **Erosion Prevention and Control.** Contractor's operations shall be conducted reasonably to minimize soil erosion. Equipment shall not be operated when ground conditions are such that excessive damage will result. Contractor shall adjust the kinds and intensity of erosion control work done, to ground conditions



and weather conditions and the need for controlling runoff. Erosion control work shall be kept current immediately preceding expected seasonal periods of precipitation or runoff.

Prior to and during periods of accelerated water runoff, especially during the spring runoff and periods of heavy rainfall, commensurate with its use, Contractor shall inspect and open culverts and drainage structures, construct special cross ditches for road runoff, and take other reasonable measures needed to prevent soil erosion and siltation of streams.

Unless otherwise agreed in writing, Contractor shall complete erosion prevention and control work, including streamcourse protection, within 15 calendar days after completion of skidding and/or yarding operations for each landing.

Designation of on the ground work shall be done as promptly as feasible unless it is agreed that the location of such work can be established without marking on the ground.

When operations are active, erosion control work will be kept current and will be completed as soon as practicable.

**16. Protection of Land Survey Monuments.** Contractor shall protect all known survey monuments, and bearing trees against avoidable destruction, obliteration, or damage during Contractor's operations. If any known monuments are, corners, or accessories are destroyed, obliterated, or damaged by Contractor's operations, Contractor shall hire the appropriate county surveyor or a registered land surveyor to reestablish or restore at the same location the monuments, corners or accessories. Such surveyors shall use procedures in accordance with the Bureau of Land Management "Manual of Instructions for the Survey of the Public Lands of the United States" for General Land Office surveys and in accordance with State law for others. Contractor shall record such survey in appropriate county records.

**17. Protection of Improvements.** So far as practicable, Contractor shall protect specified roads and other improvements (such as roads, trails, telephone lines, ditches, and fences):

- a) Existing in the operating area,
- b) Determined to have a continuing need or use, and
- c) Designated on the Map.

Contractor shall keep roads and trails needed for fire protection or other purposes and designated on the Map reasonably free of equipment and products, slash, and debris resulting from Contractor's operations. Contractor shall make timely restoration of any such improvements damaged by Contractor's operations and, when necessary because of such operations, shall move such improvements.

**18. Meadow Protection.** Reasonable care shall be taken to avoid damage to the cover, soil, and water in meadows shown on the Map. Vehicular or other equipment shall not be used on meadows, except where roads, landings, and tractor roads are approved. Unless otherwise agreed, trees felled into meadows shall be removed by hand. Resulting slash shall be removed where necessary to protect cover, soil, and water.

**19. Wetlands Protection.** Wetlands requiring protection under Executive Order 11990 are shown on the Map. Vehicular or other equipment shall not be used in such wetlands, except where roads, landings, and tractor roads are approved.

20. **Current Operating Areas.** Where logging, road construction, or other project work is in progress but not completed, unless agreed to otherwise, Contractor shall, before operations cease annually, remove all temporary log culverts and construct temporary cross drains, drainage ditches, dips, berms, culverts, or other facilities needed to control erosion. Such protection shall be provided, for all disturbed, unprotected ground that is not to be disturbed further prior to end of operations each year, including roads and associated fills, tractor roads, skid trails, and fire lines. When weather permits operations, Contractor shall keep such work on any additional disturbed areas as up to date as practicable.
21. **Erosion Control Structure Maintenance.** During the period of this Contract, Contractor shall provide maintenance of soil erosion control structures constructed by Contractor until they become stabilized, but not for more than one year after their construction.
22. **Fire Precautions and Control**
- a) **Plans.** Prior to initiating Contractor's operations during Fire Precautionary Period, Contractor shall file with UMRWA a Fire Prevention and Control Plan providing for the prevention and control of fires on the Project Area and other areas of Contractor's Operations. Such plan shall include a detailed list of personnel and equipment at Contractor disposal for implementing the plan. This requirement may be met by preparing a single plan for more than one Contract.
  - b) **Fire Precautions.** Specific fire precautionary measures listed in this Appendix shall be applicable during Contractor's Operations in "Fire Precautionary Period" described. The dates of Fire Precautionary Period may be changed by agreement, if justified by unusual weather or other conditions. Required tools and equipment shall be kept in serviceable condition and immediately available for fire fighting at all times during Contractor's operations in Fire Precautionary Period.
  - c) **Substitute Precautions.** UMRWA may authorize substitute measures or equipment, or waive specific requirements by written notice, if substitute measures or equipment will afford equal protection or some of the required measures and equipment are unnecessary.
  - d) **Emergency Precautions.** UMRWA or Forest Service may require the necessary shutting down of equipment on portions of Contractor's Operations, as specified by the emergency fire precautions schedule. Under such conditions, after Contractor cease(s) active operations, Contractor shall release for hire by Forest Service, if needed, Contractor's shutdown equipment for fire standby on the Project Area or other areas of Contractor's Operations and personnel for fire standby or fire patrol, when such personnel and equipment are not needed by Contractor for other fire fighting or protection from fire. Equipment shall be paid for at fire fighting equipment rates common in the area or at prior agreed rates and, if Contractor request(s), shall be operated only by personnel approved by the Contractor. Personnel so hired shall be subject to direction and control by Forest Service and shall be paid by Forest Service at fire fighting rates common in the area or at prior agreed rates.
  - e) **Fire Precautionary Period and Fire Precautions.** Specific fire precautionary measures are set forth below. Upon request of UMRWA, Contractor shall permit and provide an individual to assist in periodic testing and inspection of required fire equipment. Contractor shall promptly remedy deficiencies found through such inspecting and testing.
    1. The following requirements shall apply during the period May 1- December 1 and during other such periods as specified by UMRWA.

2. *See fire plan below*

23. **Fire Control.** Contractor shall, both independently and in cooperation with Forest Service, take all reasonable and practicable action to prevent and suppress fires resulting from Contractor's Operations and to suppress any forest fire on Project Area. Contractor's independent initial fire suppression action on such fires shall be immediate and shall include the use of all necessary personnel and equipment at Contractor's disposal on Project Area or within the distance of Project Area: **(Initial fire suppression within 25 road miles, and fire suppression re-inforcement within 100 miles).**
- a) **The Contractor's Reinforcement Obligations.** Whenever an Operations Fire or Negligent Fire, whether on or off Project Area or any other forest fire on Project Area, has not been suppressed by initial action and appreciable reinforcement strength is required, UMRWA may require further actions by Contractor until such fire is controlled and mopped up to a point of safety. Such actions may include any or all of the following as necessary to fight such fire:
- b) **Suspend Operations.** To suspend any or all of Contractor's Operations.
- c) **Personnel.** To release for employment by Forest Service any or all of Contractor's personnel engaged in Contractor's Operations or timber processing within the distance of Project Area: **(25 Road miles).** Any organized crew so hired shall include Contractor's supervisor, if any. Personnel so employed shall be paid at Forest Service standard emergency fire fighting rates.
- d) **Equipment.** To make available for Forest Service rental at fire fighting equipment rates common in the area or at prior agreed rates any or all of Contractor's equipment suitable for fire fighting and currently engaged in Contractor's Operations within the distance of Project Area: **(100 Road miles).** Equipment shall be operated only by personnel approved by Contractor, if so requested by Contractor.
- e) **Operations Fire.** An "Operations Fire" is a fire caused by Contractor's Operations, in the course of fulfilling the Contract, other than a Negligent Fire.

Contractor agrees to reimburse UMRWA for the cost for each Operations Fire, subject to a maximum of the dollar amount stated herein. The cost of Contractor's actions, supplies, and equipment on any such fire provided pursuant to this Contract, or otherwise at the request of UMRWA or Forest Service, shall be credited toward such maximum. If Contractor's actual cost exceeds its fire liability limit stated herein, Forest Service, through UMRWA, shall reimburse Contractor for the excess.

Maximum Amount of Contractor's Obligation per Operation's Fire.

**Contractor's Obligation per Operations Fire,**

**Maximum**

**Amount:** \_\_\_\_\_ \$27,600

- f) **Negligent Fire.** A "Negligent Fire" is a fire caused by carelessness or fault of Contractor's Operations, including, but not limited to, one caused by smoking by persons engaged in Contractor's Operations during the course of their service, or during rest or lunch periods; or if Contractor's failure to comply with the requirements of **17. Fire Precautions and Control** results in a fire starting or permits a fire to spread. Damages and the cost of suppressing Negligent Fires shall be borne by Contractor.

## FIRE PLAN

### 1. **SCOPE:**

The provisions set forth below outline the responsibility for fire prevention and suppression activities and establish a suppression plan for fires within the Contract area. The Contract area is delineated by map in the Contract. The provisions set forth below also specify conditions under which Contract activities will be curtailed or shut down.

### 2. **RESPONSIBILITIES:**

#### A. Contractor

(1) Shall abide by the requirements of this Fire Plan.

(2) Shall take all steps necessary to prevent his/her employees, subcontractors and their employees from setting fires not required in completion of the Contract, shall be responsible for preventing the escape of fires set directly or indirectly as a result of Contract operations, and shall extinguish all such fires which may escape.

(3) Shall permit and assist in periodic testing and inspection of required fire equipment. Contractor shall certify compliance with specific fire precautionary measures in the fire plan, before beginning operations during Fire Precautionary Period and shall update such certification when operations change.

(4) Shall designate in the Fire Plan and furnish on Contract Area, during operating hours, a qualified fire supervisor authorized to act on behalf of Contractor in fire prevention and suppression matters.

#### B. UMRWA

UMRWA may conduct one or more inspections for compliance with the Fire Plan. The number, timing, and scope of such inspections will be at the discretion of personnel responsible for Contract administration. Such inspections do not relieve the Contractor of responsibility for correcting violations of the fire plan or for fire safety in general.

### 3. **DEFINITIONS:**

**Active Landing:** A location the Contractor may be skidding logs into, or performing other operations such as delimiting, log manufacturing, and chipping logs. Except for EV and E days, loading logs or stockpiling chips only, on a cleared landing, does not constitute an Active Landing.

**Hot Saw:** A harvesting system that employs a high-speed (>1100 rpm) rotating felling head, i.e., full rotation lateral tilt head.

**Mechanical Operations:** The process of felling, skidding, chipping, shredding, masticating, piling, log processing and/or yarding which requires the use of motorized power which includes, chainsaws, chippers, motorized carriages, masticators, stroke delimiters, skidders, dozers etc.

#### 4. **TOOLS AND EQUIPMENT:**

The Contractor shall comply with the following requirements during the fire precautionary period, as defined by unit administering contracts:

**The Fire Precautionary Period is set by the State of California which is April 1 through December 1 of any year.**

**A. Fire Tools and Equipment:** Contractor shall meet minimum requirements of Section 4428 of the California Public Resources Code (C.P.R.C.). Fire tools kept at each operating landing shall be sufficient to equip all employees in the felling, yarding, loading, chipping, and material processing operations associated with each landing. Fire equipment shall include two tractor headlights for each tractor dozer used in Contractor's Operations. Tractor headlights shall be attachable to each tractor and served by an adequate power source. All required fire tools shall be maintained in suitable and serviceable condition for firefighting purposes.

Trucks, pickups and other similar mobile equipment shall be equipped with and carry at all times a size 0 or larger shovel with an overall length of not less than 46 inches and a 2-1/2 pound axe or larger with an overall length of not less than 28 inches.

**B. Fire Extinguishers:** Contractor shall equip each internal combustion fuel truck with a fire extinguisher for oil and grease fires (4-A:60-B:C).

Skidders and tractors shall be equipped with a minimum 5-BC fire extinguisher.

All Fire Extinguishers shall be mounted, readily accessible, properly maintained and fully charged.

Contractor shall equip each mechanized harvesting machine with hydraulic systems, powered by an internal combustion engine (chipper, feller/buncher, harvester, forwarder, hot saws, stroke delimber, etc), except tractors and skidders, with at least two 4-A:60-B:C fire extinguishers or equivalent.

**C. Spark Arresters and Mufflers:** Contractor shall equip each internal combustion engine with a spark arrester, except for motor vehicles equipped with a maintained muffler as defined in C.P.R.C. Section 4442. Spark Arresters shall be a model tested and approved under Forest Service Standard 5100-1a as shown in the. National Wildlife Coordinating Group Spark Arrester Guide, Volumes 1 and 2, and shall be maintained in good operating condition. Every motor vehicle subject to registration shall at all times be equipped with an adequate exhaust system meeting the requirements of the California Vehicle Code.

**D. Power Saws:** Each power saw shall be equipped with a spark arrester approved according to C.P.R.C. Section 4442 or 4443 and shall be maintained in effective working order. An Underwriters Laboratories (UL) approved fire extinguisher containing a minimum 14 ounces of fire retardant shall be kept with each operating power saw. In addition, a size 0 or larger shovel with an overall length of not less than 38 inches shall be kept with each gas can but not more than 300 feet from each power saw when used off cleared landing areas.

**E. Tank Truck or Trailer:** Unless waived in writing by the Forest Service, Contractor shall provide a **water tank truck or trailer** on or in proximity to Contract Area during Contractor's Operations hereunder during Fire Precautionary Period. When Project Activity Level B or higher is in effect, a tank truck or trailer shall be on or immediately adjacent to each active unit. See Section 6 for specific Contract requirements.

The tank shall contain at least 300 gallons of water available for fire suppression. Ample power and hitch shall be readily available for promptly and safely moving tank over roads serving Contract Area. Tank truck or trailer shall be equipped with the following:

- (1) Pump, which at sea level, can deliver 23 gallons per minute at 175 pounds per square inch measured at the pump outlet. Pumps shall be tested on Contract Area using a 5/16 inch orifice in the Forester One Inch In-Line Gauge test kit. Pump shall meet or exceed the pressure value in the following table for nearest temperature and elevation:

T e m p	Sea Level	1000 Feet		2000 Feet		3000 Feet		4000 Feet		5000 Feet		6000 Feet		7000 Feet		8000 Feet		9000 Feet		10000 Feet		
55	179	23	174	23	169	23	165	22	161	22	157	22	153	22	150	21	146	21	142	21	139	21
70	175	23	171	23	166	22	162	22	158	22	154	22	150	21	147	21	143	21	139	21	136	20
85	171	23	168	23	163	22	159	22	155	22	151	21	147	21	144	21	140	21	136	20	133	20
100	168	23	164	23	159	22	155	22	152	22	148	21	144	21	141	21	137	20	133	20	131	20
	P S I	G P M	P S I	G P M	P S I	G P M	P S I	G P M	P S I	G P M	P S I	G P M	P S I	G P M	P S I	G P M	P S I	G P M	P S I	G P M	P S I	

The pump outlet shall be equipped with 1-1/2 inch National Standard Fire Hose thread. A bypass or pressure relief valve shall be provided for other than centrifugal pumps.

- (2) 300 feet of 3/4-inch inside diameter rubber-covered high-pressure hose mounted on live reel attached to pump with no segments longer than approximately 50 feet, when measured to the extreme ends of the couplings. Hose shall have reusable compression wedge type 1-inch brass or lightweight couplings (aluminum or plastic). One end of hose shall be equipped with a coupling female section and the other end with a coupling male section. The hose shall, with the nozzle closed, be capable of withstanding 200 PSI pump pressure without leaking, distortions, slipping of couplings, or other failures.
- (3) A shut-off combination nozzle that meets the following minimum performance standards when measured at 100 P.S.I. at the nozzle:

	G.P.M.	Horizontal Range
Straight Stream	10	38 feet
Fog Spray	6 - 20	N/A

- (4) Sufficient fuel to run the pump at least 2 hours and necessary service accessories to facilitate efficient operation of the pump.

**This equipment and accessories shall be deliverable to a fire in the area of operations and is subject to the requirements for each specific activity level identified in Section 6.**

**F. Compressed Air Foam System:** A Compressed Air Foam System (CAFS) is a fire suppression system where compressed air is added to water and a foaming agent. By agreement, Contractor may substitute a CAFS or functional equivalent in lieu of the tank truck, trailer or fire extinguishers, provided it meets or exceeds the following specifications and requirements:

- 1. Variable foam expansion ratio – 10:1 to 20:1.

2. Units shall be kept fully charged with air; water and foam concentrate as recommended by the manufacturer and have the appropriate tools to service the system.
3. The unit shall contain enough energy to empty tank and clear hose prior to exhausting propellant.
4. The unit shall be capable of being completely recharged within 10 minutes.
5. When used on cable yarding landings, the unit shall be outfitted for immediate attachment to carriage and transported without damage to the unit.

Fire extinguishers required for Hot Saws, Masticators and similar equipment identified in Section 4 B. above may be substituted with a 3 gallon CAFS.

Tank truck, trailer or equivalent may be substituted with a 30 Gallon CAFS with at least 550 feet of one inch hose and an adjustable nozzle with enough water, air and foam concentrate for at least one recharge.

**This equipment and accessories shall also be deliverable to a fire in the area of operations and subject to the requirements for each specific activity level identified in Section 6.**

5. **GENERAL**

- A. **State Law:** In addition to the requirements in this Fire Plan, the Contractor shall comply with all applicable laws of the State of California. In particular, see California Public Resource Codes.
- B. **Permits Required:** The Contractor must secure a special written permit from the Forest Service District Ranger or designated representative before burning, welding or cutting metal or starting any warming fires. If Contract requires Blasting and Storing of Explosives and Detonators, an Explosives Permit may be required pursuant to the California Health and Safety Code, Section 12101.
- C. **Smoking:** Smoking shall not be permitted during fire season, except in a barren area or in an area cleared to mineral soil at least three feet in diameter. In areas closed to smoking, UMRWA may approve special areas to be used for smoking. The Contractor shall sign designated smoking areas. Contractor shall post signs regarding smoking and fire rules in conspicuous places for all employees to see. Contractor's supervisory personnel shall require compliance with these rules. Under no circumstances shall smoking be permitted during fire season while employees are operating light or heavy equipment, or walking or working in grass and woodlands.
- E. **Storage and Parking Areas.** Equipment service areas, parking areas, and gas and oil storage areas shall be cleared of all flammable material for a radius of at least 10 feet unless otherwise specified by local administrative unit. Small mobile or stationary internal combustion engine sites shall be cleared of flammable material for a slope distance of at least 10 feet from such engine. UMRWA shall approve such sites in writing.
- F. **Reporting Fires:** As soon as feasible but no later than 15 minutes after initial discovery, Contractor shall notify Forest Service of any fires on Contract Area or along roads used by Contractor. Contractor's employees shall report all fires as soon as possible to UMWRA and any of the following Forest Service facilities and/or personnel listed below, but not necessarily in the order shown:

	Name	Office Address	Office telephone

<b>Dispatch Center</b>	<b>Office 24 Hour</b>		<b>209-533-1130/1140</b> <b>209-532-3786</b>
Nearest Station	FS	Calaveras R.D	Hathaway Pines 209-795-1381
Inspector		TBD	
UMRWA		Rob Alcott	Valley Springs 707-785-1008
District Ranger		Ray Cablayan	Hathaway Pines 209-813-6017

**When reporting a fire, provide the following information:**

- Your Name
- Call back telephone number
- Project Name
- Location: Legal description (Township, Range, Section); and Descriptive location (Reference point)
- Fire Information: Including Acres, Rate of Spread and Wind Conditions.

- G. **Communications:** Contractor shall furnish a serviceable telephone, radio-telephone or radio system connecting each operating side with Contractor's headquarters. When such headquarters is at a location which makes communication to it clearly impractical, UMRWA may accept a reasonable alternative location. The communication system shall provide prompt and reliable communications between Contractor's headquarters (or agreed to alternative) and UMRWA via commercial or telephone.
- H. **Fire Patrolperson:** Contractor shall furnish a qualified fire patrolperson each operating day when Project Activity Level C or higher is in effect. When on duty, sole responsibility of patrolperson shall be to patrol the operation for prevention and detection of fires, take suppression action where necessary and notify UMRWA and the Forest Service as required. This Fire patrol is required on foot, unless otherwise agreed. By agreement, one patrolperson may provide patrol on this and adjacent projects.

The Contractor shall, prior to commencing work, furnish the following information relating to key personnel:

Title	Name	Telephone Number
Fire Supervisor		
Fire Patrolperson		

- I. **Clearing of Fuels:** Contractor shall clear away, and keep clear, fuels and logging debris as follows:

Welding equipment and stationary log loaders, yarders and other equipment listed in California State Law:	10 feet slope radius
---	----------------------

## 6. EMERGENCY PRECAUTIONS



Contractor's Operations shall conform to the limitations or requirements in the Project Activity Level (PAL) table below. Project Activity Levels applicable to this project shall be the predicted activity levels for the Fire Danger Rating Area(s), or fire weather station(s) stated herein.

**Fire Danger Rating Area/Fire Weather Station for Project (Forest Service)**     HIGH/ North

The Forest Service, in its sole discretion, may change the predicted activity level if the current fire suppression situation, weather and vegetation conditions warrant an adjustment. If practicable, Forest Service will determine the following day's activity level by 6:00 PM. Contractor shall obtain the predicted Project Activity Level from the appropriate Ranger District Office before starting work each day.

**Phone Number or Website to obtain Predicted Activity Levels:**     209-532-5601 (Stanislaus Dispatch)

Forest Service may change the Project Activity Level Table to other values upon revision of the National Fire Danger Rating System. When Contractor is notified, the revised Project Activity Levels will supersede the levels in the Project Activity Level Table below.

#### PROJECT ACTIVITY LEVEL

<b>Level</b>	<b><i>Project Activity Minimum Requirements and Restrictions. Restrictions at each level are cumulative.</i></b>
<b>A</b>	Minimum requirements noted above in Sections 4 and 5.
<b>B</b>	1. Tank truck, trailer, or approved CAFS substitute shall be on or adjacent to the Active Landing.
<b>C</b>	1. When Hot Saws or Masticators are operating, a tank truck, trailer, or approved CAFS substitute shall be within ¼ mile of these operations. Effective communications shall exist between the operator and the Active Landing.  2. Immediately after Mechanical Operations cease, Fire patrol is required for two hours.
<b>D</b>	1. Immediately after Hot Saw or Masticator operations cease, Fire patrol is required for three hours.  2. No Dead Tree felling after 1:00 PM, except recently dead.  3. No burning, blasting, welding or cutting of metal after 1:00 PM, except by special permit.

<b>Level</b>	<b><i>Project Activity Minimum Requirements and Restrictions. Restrictions at each level are cumulative.</i></b>
<b>Ev</b>	<p>1. The following activities may operate all day:</p> <ol style="list-style-type: none"> <li>a) Loading and hauling logs decked at approved landings.</li> <li>b) Loading and hauling chips stockpiled at approved landings.</li> <li>c) Servicing equipment at approved sites.</li> <li>d) Dust abatement, road maintenance (Chainsaw use prohibited), culvert installation within cleared area, chip sealing, paving, earth moving or rock aggregate stock pile loading and installation (does not include pit or quarry development).</li> <li>e) Chainsaw and log processing operations associated with loading logs or other forest products at approved landings.</li> </ol> <p>2. Hot Saws or Masticators may operate until 1:00 PM; provided that:</p> <ol style="list-style-type: none"> <li>a) A tractor or other equipment with a blade capable of constructing fireline is on or adjacent to the active landing or within ¼ mile of the operating equipment. This piece of equipment shall have effective communication with the Hot Saw or Masticator.</li> <li>b) Any additional restrictions specified by the Forest.</li> </ol> <p>3. All other conventional Mechanical Operations are permitted until 1:00 PM.</p> <p>4. Some operations may be permitted after 1:00 PM, on a case-by-case basis, under the terms of a PAL Ev Variance Agreement. Activities for which a Variance may be issued are:</p> <ul style="list-style-type: none"> <li>• Rubber Tire Skidding</li> <li>• Chipping on Landings</li> <li>• Helicopter Yarding</li> <li>• Fire Salvage</li> </ul> <p>When approved by UMWRA and a Forest Service Line Officer, a Variance Agreement can be implemented when the criteria specified in the agreement are met and mitigation measures are in place. This approval is good for ten (10) days unless cancelled sooner or extended by UMWRA and the Forest Service for an additional ten (10) days. Variance approval can be withdrawn at the sole discretion of UMWRA or the Forest Service. Variance approval is contingent on the 7-day fire weather forecast, fuel conditions, site characteristics, current fire situation, state of Contractor's equipment for prevention and suppression readiness, type of operation and social and community considerations etc. (See attached Project Activity Level Variance Agreement).</p>

<b>Level</b>	<b><i>Project Activity Minimum Requirements and Restrictions. Restrictions at each level are cumulative.</i></b>
<b>E</b>	<p>The following activities may operate all day:</p> <ol style="list-style-type: none"> <li>1. Loading and hauling logs decked at approved landings.</li> <li>2. Loading and hauling chips stockpiled at approved landings.</li> <li>3. Servicing Equipment at approved sites.</li> <li>4. Dust abatement, road maintenance (chainsaw use prohibited) or loading stock piles and rock aggregate installation (does not include pit or quarry development).</li> <li>5. Chainsaw operation associated with loading at approved landings.</li> </ol> <p>All other activities are prohibited.</p>

**This Project utilizes “The Project Activity Level” (PAL), an industrial operation’s fire precaution system. The following Climatology Chart indicates the Historic Activity Levels for the Project Fire Danger Rating Area or Fire Weather Station utilized on this Project. This is only a historical average of the Activity Levels for the identified Fire Danger Rating Area or Weather Station.**

The Project Activity Level (PAL), and industrial operations fire precaution system will be used for this project. The PAL Zone High North RAWS will be used to calculate the Project Activity Level. The normal operating season is May 1 through October 31. The expected days per month at each PAL value for the normal operation season is shown in the following table:

<b>Project Activity Level 2010</b>						
Station/SIG/Unit:	PAL Zone High North			STF	Years Analyzed: 2009-2011	
	A	B	C	D	Ev	E
Month	Expected Days per Month at each PAL Level					
April	24	4	2	0	0	0
May	23	5	2	2	0	0
June	12	9	9	1	0	0
July	0	4	17	6	4	0
August	0	1	10	11	9	0
September	0	2	7	9	12	0
October	7	6	16	2	1	0
November	10	8	6	4	1	0



# Cabbage Patch Mastication Stanislaus National Forest Calaveras Ranger District Project Area Map

### Legend

- Contract Boundary
- Treatment Units
- Cutting Units
- CA-1 Protection
- Watersource
- Protection of Improvements, Buried Power Line
- Protection of Improvements, Fences
- Protection of Improvements, Other Ownership
- Protection of Meadows
- Protection of Improvements, Survey Monument
- Protection of Improvements, Cattle Guards and Gates
- Streamcourse Protection, (Perennial, Intermittent and Ephemeral Streams), Mastication Equipment (All Types) - 15 foot exclusion zone,
- CA-3, Controlled Area, No Operations between March 1 and August 15 (CA Spotted Owl)
- CA-4, Controlled Area, No Operations between February 15 - Sept 15 (NOGO)



Landlines and Symbol Locations are Approximate  
Weather Station, PAL Zone High North



mms 5/23/2018

